



**ballina**  
shire council

# ***on-site sewage management guidelines***

07/2017



***ballina***  
shire council

40 cherry street • po box 450 • ballina nsw 2478  
t 1300 864 444 • f 02 6686 7035 • e [council@ballina.nsw.gov.au](mailto:council@ballina.nsw.gov.au)

***[ballina.nsw.gov.au](http://ballina.nsw.gov.au)***

# OSSM GUIDELINES

## TABLE OF CONTENTS

<b>INTRODUCTION</b>	<b>6</b>
<b>BALLINA - LOCAL CONTEXT</b>	<b>7</b>
Status of Richmond Ecohealth Project - Assessment of River and Estuarine Condition	8
<b>BRIEF HISTORY OF BALLINA SHIRE COUNCIL'S OSSM PROGRAM</b>	<b>10</b>
<b>OSSM PROGRAM - PRIMARY PERFORMANCE OBJECTIVES</b>	<b>10</b>
Public Health	10
Environment	10
Community Amenity	10
Resource Utilisation	10
<b>ROLES AND RESPONSIBILITIES</b>	<b>11</b>
Homeowner and Occupiers	11
Local Government	12
NSW Ministry of Health	12
OSSM Designer	13
OSSM Installation Contractor	13
OSSM Service Agent	13
<b>OSSM APPROVAL TO INSTALL, CONSTRUCT, ALTER APPLICATION</b>	
<b>- REQUIREMENTS</b>	<b>14</b>
<b>OSSM Design Report - Key Components</b>	<b>14</b>
Desktop Study	14
Climate Data	15
Rous Water and BSC Drinking Water Catchment Areas	16
Priority Oyster Aquaculture Areas	18
Soil Landscape Maps	20
Groundwater Bores	22
OSSM and Flood Level Requirements	22
Acid Sulfate Soils	23
Site and Soil Evaluation	24
Modified Aggregate Stability Test for On-Site Wastewater Assessment	27
Recommended Setback Distances for Effluent Land Application Areas	28
<b>SIZING OF OSSM SYSTEMS</b>	<b>29</b>
Calculating Wastewater Volumes and Equivalent Population (EP)	29
<b>OSSM EFFLUENT LAND APPLICATION AREA CALCULATIONS</b>	<b>35</b>
Wisconsin Sand Mound Systems	37
<b>WICK TRENCHES</b>	<b>40</b>

CONTINUES OVER THE PAGE

# OSSM GUIDELINES

## TABLE OF CONTENTS

<b>SITE PLANS</b>	<b>42</b>
<b>PLUMBING AND DRAINAGE AND ASSOCIATED PIPEWORK</b>	<b>42</b>
<b>BACKFLOW PREVENTION IN NON-SEWERED AREAS</b>	<b>43</b>
<b>OSSM AND MOBILE VENDING (FOOD) REQUIREMENTS</b>	<b>43</b>
Ecologically Sustainable Development	44
<b>OSSM OPERATION AND MAINTENANCE PLANS</b>	<b>45</b>
<b>OSSM CERTIFICATION</b>	<b>45</b>
Guide for Swimming Pool and Spa Bath Backwash and Overflow Discharges - For Non-Sewered Areas	46
Existing Properties in Non-Sewered Area - Proposal to Connect into Council's Sewerage System	47
<b>APPROVAL TO OPERATE APPLICATION - REQUIREMENTS</b>	<b>47</b>
<b>DEVELOPMENT APPLICATION REQUIREMENTS</b>	<b>48</b>
<b>EXISTING OSSM INSPECTION PROCESS</b>	<b>50</b>
<b>DEMAND DOSE PUMP WELL</b>	<b>51</b>
<b>DOSING SIPHON &amp; FLOUT</b>	<b>52</b>
<b>TYPICAL ETA BED INSTALLATION</b>	<b>53</b>
<b>APPENDIX A - AN IMPROVED VIRAL DIE-OFF METHOD</b>	<b>54</b>
<b>APPENDIX B - THE RADIUS OF INFLUENCE OF A WATER BORE</b>	<b>57</b>
<b>APPENDIX C - ETA BED NUTRIENT BALANCE EXAMPLE</b>	<b>59</b>
<b>APPENDIX D - ETA BED WATER BALANCE EXAMPLE</b>	<b>60</b>
<b>DEFINITIONS</b>	<b>62</b>



*on-site sewage  
management  
**guidelines***



# INTRODUCTION

Ballina Shire Council's (BSC) On-Site Sewage Management (OSSM) Strategy and Guidelines have been developed and reviewed in accordance with the requirements of the NSW Department of Local Government. These requirements were originally introduced as part of a package of local government regulatory reforms and guidelines in 1998 to enable Local Government to more effectively regulate and supervise the performance of OSSM systems.

OSSM systems treat the wastewater generated from premises located in non-sewered regions and apply the effluent into the environment (land) via sub-surface methods. Typical OSSM systems include septic tanks, aerated wastewater treatment systems, composting toilets, reed beds, sand filters, biological filters, and greywater systems. The treated wastewater (effluent) is applied to the land according to the site constraints utilising various land application methods ie absorption/evapotranspiration beds and trenches, Wisconsin sand mounds and subsurface irrigation systems. Surface irrigation of effluent is not permitted within the BSC LGA for all new OSSM systems, however if the property owner has an existing approved surface irrigation system then this system may continue to operate in this way as long as the system is regularly serviced, maintained and operates satisfactorily.

These Guidelines provide essential information for applicants, designers, installers, homeowners and the community about how Council approves, manages and monitors OSSM systems. The Guidelines detail the information that must be included with an application to install, construct, alter or operate an OSSM system. Wherever possible the Guidelines will refer to Australian Standards and other technical documents for processes and assessment methods. The Guidelines will focus on providing OSSM designers and installers with local particulars and clarifications.

A key component of the OSSM Program will be educating the OSSM homeowner and user in the importance of monitoring their OSSM system to maintain satisfactory performance. Separate educational documentation will be developed and distributed to the homeowner to achieve this outcome. OSSM systems that are not performing satisfactorily may lead to significant environmental and public health issues.

The long term viability and satisfactory performance of each OSSM system is fundamental in minimising any potential adverse impacts to public health and our precious local environment. BSC is committed to continually improve the management of the OSSM Program and to streamline the application approval process. These Guidelines have been written for a specific audience, targeting OSSM designers, NSW licenced plumbers & drainers (installers) and OSSM service agents.



# BALLINA - LOCAL CONTEXT

The BSC LGA is located within the Northern Rivers region of New South Wales, the traditional country of the Bundjalung people. Our main town and commercial centre is Ballina, with other major population centres including Lennox Head, Alstonville, Wollongbar and Wardell. There are also a number of small villages along the coast and throughout the hinterland. The coast, the Richmond River, the escarpment, and the plateau are four of the standout features for our shire.

These locations, with their associated waterways, natural habitats, farming landscape and cultural and heritage values, along with the beaches and ocean, help to define our place and communities. About 93% of the shire is zoned rural or environmental protection. A large proportion of the remaining native vegetation is located on private land, with 2% of the shire being National Park or Nature Reserve.

The total area of the shire is 485 square kilometres (48,490 ha) and approximately 60% of the shire is less than 20 metres above sea level. Only 20% of the shire is above 100 metres elevation.

About 16% of the Richmond River and its sub-catchments are in good or very good condition, with over a third of the river and catchments being in poor or very poor condition. Improvement in the overall health of the Richmond River is one of the key outcomes for our community.

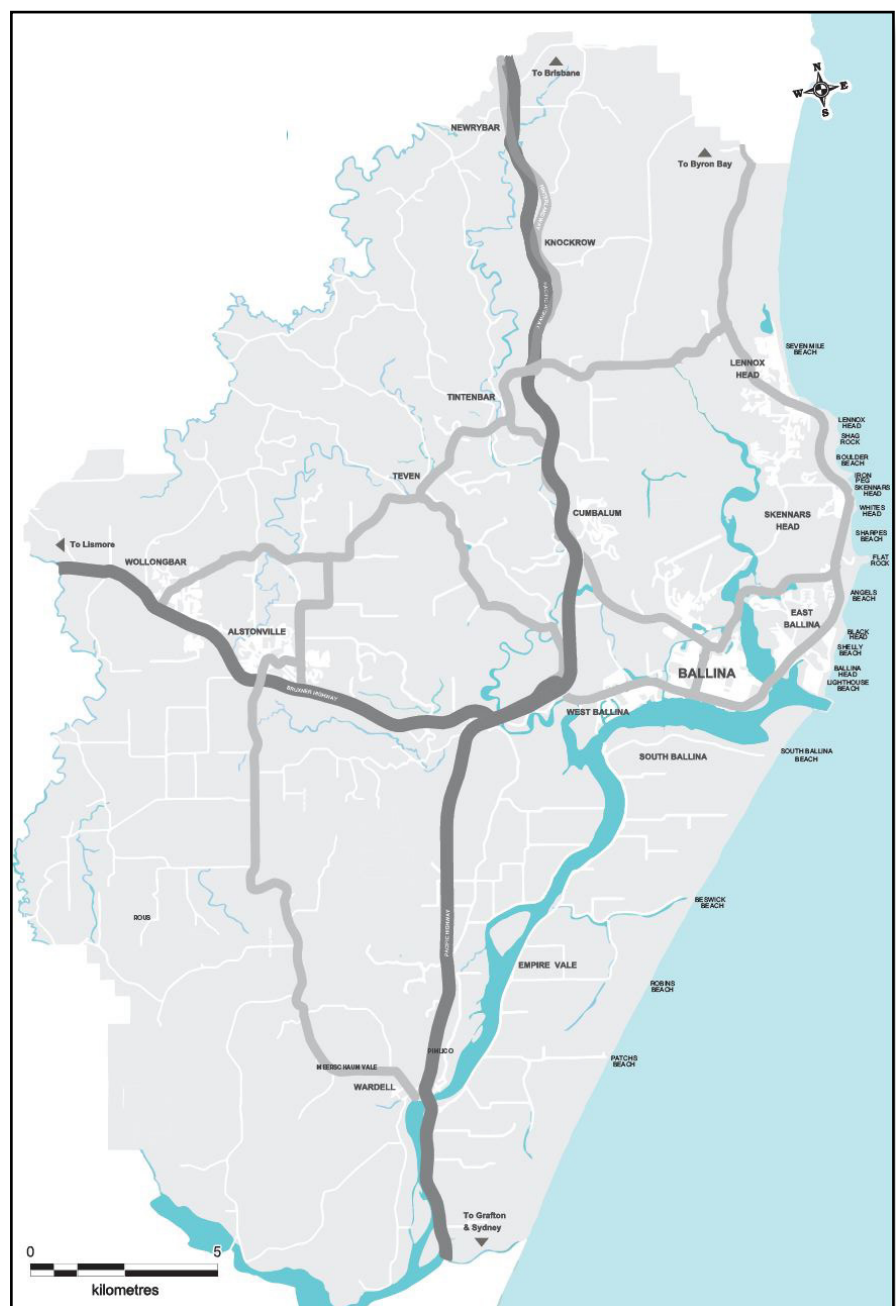

## Status of Richmond Ecohealth Project - Assessment of River and Estuarine Condition

The Richmond Ecohealth Project (2014) brought together many stakeholders to develop, refine, report and promote a standardised river and estuary health assessment tool for the Richmond catchment. BSC is one of the stakeholders and the OSSM Program plays a part in catchment management. The Richmond Ecohealth Project has completed a technical report (University of New England, 2015) in regard to the condition of the Richmond Region, River and Estuarine catchments. The Report has detailed many contributing factors to the current poor 'Ecohealth' status of our Rivers and Estuarine catchments.

### Extract from Richmond Ecohealth Project – Final Technical Report (UNE, 2015):

*“The Overall Grade for the Richmond catchment was D+ (Table 3.1, Figure 3.1), ranging from an F in the Wilsons River and upper Richmond estuary to a C in the headwater streams of the catchment. The upper freshwater reaches of the Richmond main stem (river) had better water quality, aquatic macroinvertebrates and geomorphic condition than the lower freshwater reaches, but no better riparian condition (Table 3.1, Figure 3.2). Scores were consistent among indicators within each system, highlighting the issues with water quality, biota and physical condition are affecting short and long-term condition of the streams.”*

**TABLE 3.1 Catchment and subcatchment Ecohealth grades for the Richmond.**

SYSTEM	Water Quality	Aquatic Macroinvertebrates	Riparian	Geomorphic	Overall
Richmond River	F	D	D-	D+	D-
Upper Richmond FW	D+	B-	D	B	C
Lower Richmond FW	D-	F	D+	D+	D
Upper Richmond Estuary	F		F	F	F
Lower Richmond Estuary	F		D-	D-	D-
Rocky Mouth Creek	F		F	C-	D
Wilsons River	F		D-	C-	F
Leycester Creek	F	D	D-	C+	D
Coopers Creek	D+	C-	C+	D+	C-
Terania Creek	C-	D	C-	C+	C-
Byron Creek	D-	D-	F	C-	D-
Wilson Creek	C-	C	B-	C-	C
Eden Creek	D-	F	D+	C-	D
Iron Pot Creek	D+	C	C	C	C
Shannon Brook	F	D+	C-	D+	D-
Bungawalbin Creek	F	F	D+	B-	D
Myrtle Creek	D+	D+	B-	C	C
Sandy Creek	F	D-	D	C	D
Emigrant Creek	D-	C	D-	D+	D
Maguires Creek	D+	C	F	D+	D+
North Creek	D-		D	C	D+

Source: Ryder, D., Mika, S., Richardson, M., Schmidt, J. and Fitzgibbon, B. (2015). Richmond Ecohealth Project 2014: Assessment of River and Estuarine Condition. Final Technical Report. University of New England, Armidale.



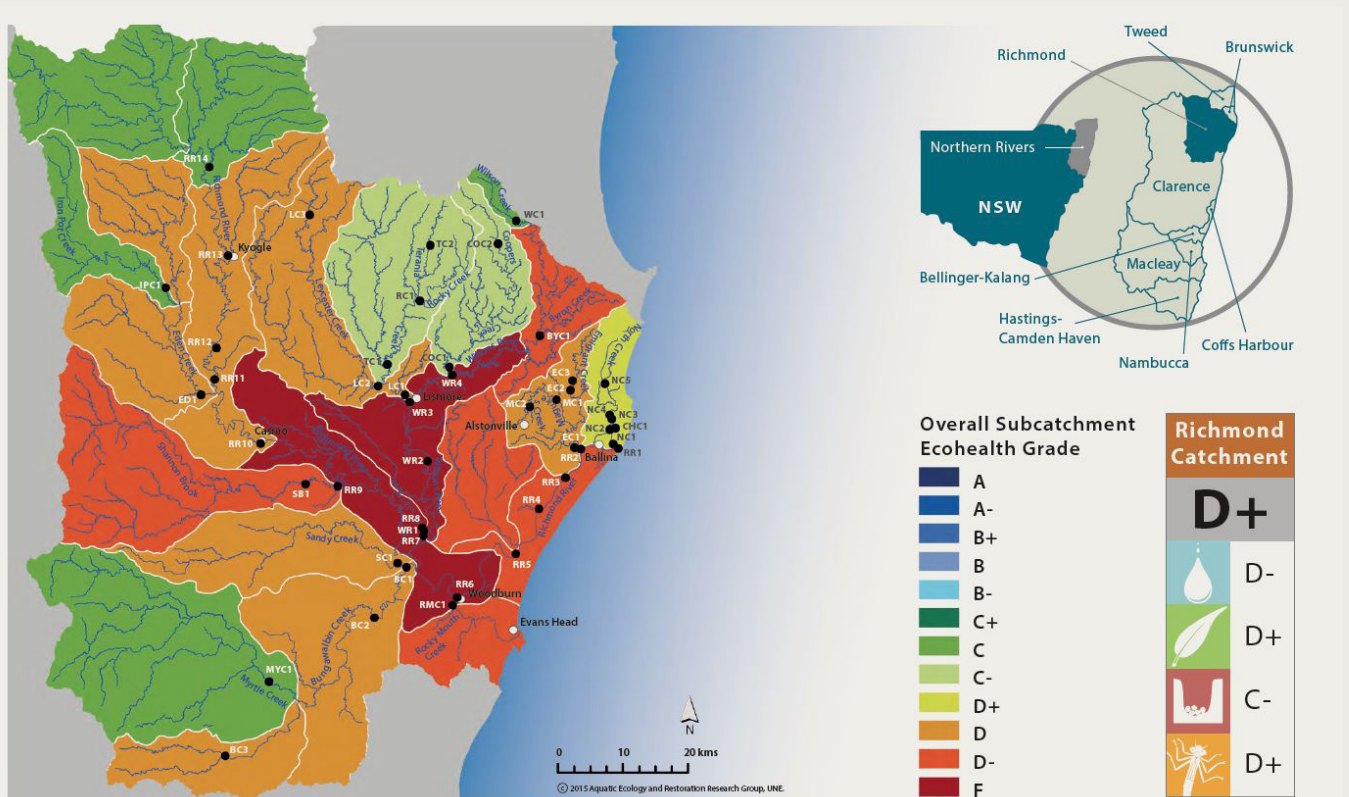

## Richmond Catchment Report Card (2014)



Condition Score	Grade	Result
91-100	A	Excellent
76-90	B	Good
61-75	C	Fair
46-60	D	Poor
0-45	F	Very Poor

**Water Quality** provides an understanding of how changes in land use practices within the catchment are affecting the health of our rivers and estuaries. Ecohealth measures oxygen level, salinity, acidity, murkiness (turbidity) and nutrients in our waterways. 

**Riparian vegetation** is important for maintaining good water quality, stabilising riverbanks and providing habitat for animals including macroinvertebrates and fish. Ecohealth looks at the occurrence of weeds, structure of riparian vegetation, habitat (e.g. fallen logs) and current management (e.g. fencing). 

**Geomorphic condition** assesses bank condition (e.g. slope, bank failure, exposed tree roots and undercutting), bed condition (e.g. active erosion and smothering of the bed substrate by high loads of fine sediment), and trampling by stock. 

**Macroinvertebrates** are waterbugs such as worms, beetles, mayflies and shrimps that are sensitive to changes in aquatic habitat, pollution and poor water quality. Ecohealth looks at the types of waterbugs occurring at different freshwater sites in our rivers. Waterbugs are not assessed in estuaries. 



# BRIEF HISTORY OF BALLINA SHIRE COUNCIL'S OSSM PROGRAM

- 1998 – NSW Department of Local Government introduced requirements for Local Councils to improve the supervision of OSSM systems and develop a Strategy
- 1999 - BSC document – Minimum Standards for the Design of On-Site Septic Wastewater Disposal Systems
- 1999 – Richmond and Tweed Catchments document - Assessment/Design Guide for the Approval of On-Site Management Systems
- 2001 – BSC document - On-Site Sewage Management Plan/Strategy
- 2008 – BSC document - On-Site Sewage and Wastewater Management Strategy
- 2017 – BSC document – On-Site Sewage Management Strategy
- 2017 – BSC document – On-Site Sewage Management Guidelines

## OSSM PROGRAM - PRIMARY PERFORMANCE OBJECTIVES

### Public Health

To protect public health, the OSSM system shall be designed and managed to:

- Minimise the health risks associated with the assimilation of human waste and domestic wastewater in the environment;
- Avoid the potential for public health nuisances;
- Avoid the potential for disease, including those that can be transmitted by ingestion, direct contact, vectors, and airborne droplets;
- Sustainably assimilate pathogens;
- Avoid transmission of pathogens and deleterious chemicals to surface and groundwater; and
- Monitor risks to public health.

### Environment

To protect the environment, the OSSM system shall be designed and managed to:

- Avoid soil instability, sustainably assimilate nutrients and other dissolved salts;
- Maintain soil productivity and sustainable use of soils;
- Contain any adverse effects within the property boundaries;

- Avoid adverse effects on surface and groundwater flows;
- Avoid pollution of groundwater and surface water such that subsequent use of the water is not compromised;
- Avoid foul odours;
- Minimise the cumulative adverse effects; and
- Monitor risks to the environment.

### Community Amenity

To protect community amenity, the OSSM system shall be designed and managed to:

- Avoid detracting from property and neighbourhood community values; and
- Be designed to take account of social and cultural values of stakeholders.

### Resource Utilisation

The OSSM system shall be designed and managed to use materials and energy efficiently during construction, installation, and operation.

These performance objectives describe what is required to achieve sustainable management of OSSM systems and have been sourced from AS/NZS 1547 – On-site domestic wastewater management.

# ROLES AND RESPONSIBILITIES

## Homeowner and Occupiers

**It is the responsibility of the owner or occupier of the premises that has an OSSM system to ensure that:**

1. OSSM systems are designed, installed and managed so that pollution of land, groundwater or surface waters does not occur;
2. There is no risk to public health, safety, amenity and the environment from the operation of an OSSM system.

Homeowners must take an active role in the operation of OSSM systems, should have a broad knowledge of OSSM principles and be able to apply that knowledge responsibly.

Homeowners should have a sound understanding of the operating requirements of the system they are using and should be aware of the need to adjust household activities accordingly (eg by using low phosphorous detergents, minimising use of household chemicals, conserving water and avoiding 'shock loading' eg spread laundry washing over the week and not perform multiple washing loads in one day).

Correct operation involves regular supervision and system maintenance. Homeowners also need to ensure that the necessary service and maintenance contracts are in place.

If an OSSM system is defective and cannot be corrected by proper operation and maintenance, the homeowners should report this to BSC in order to discuss possible system replacement.



### **Responsibilities of owners upon sale of the premises:**

Particular consideration should be given to the educational needs of new owners and tenants when a property with an OSSM system is sold or leased. Vendors (the owners who sell the property) must make sure the OSSM system is inspected prior to sale for satisfactory operation by a suitably qualified person. BSC and the new householder must receive the inspection report and operation/maintenance manual.

The manual should cover the following matters:

- system operation, capabilities and limitations
- operating requirements - system capacity, the importance of spreading the hydraulic load (eg spread washing machine cycles over a week) and actions to be avoided
- troubleshooting and signs of system failure - such as odours and surface ponding of wastewater
- maintenance and servicing requirements
- management of health risks
- occupational health and safety, first aid and chemical handling
- warranty and service life
- emergency telephone numbers.

## Local Government

The design, installation and operation of OSSM systems are regulated under the Local Government Act 1993.

**The Role of Local Government is to determine applications for:**

- the installation, construction or alteration of a human waste treatment device or storage facility and connected drains
- the ongoing operation of an OSSM system.

BSC conducts a monitoring program of OSSM systems within the BSC LGA to ensure that all systems continue to comply with relevant performance standards.

**BSC may issue “Orders” requiring a person:**

- to comply with an approval
- to take action to maintain premises in a healthy condition
- to store, treat or dispose of waste
- not to use or permit a human waste storage facility to be used, and/or to connect premises to a public sewer when the sewer is within 75 metres
- Orders may be given to the owner or occupier of the premises or to the person responsible for the waste or the container in which the waste is stored.



It is not BSC's role to design an OSSM installation or to recommend a particular system or manufacturer. The homeowner will need to conduct their own research and consult with their OSSM designer in regard to the options for OSSM on their property. BSC will ensure that the minimum information required under the Local Government (General) Regulation 2005 is submitted with the OSSM application to make a determination.

## NSW Ministry of Health

Under the provisions of Clauses 40 and 41, Local Government (General) Regulation 2005, a local council must not approve of the installation of certain OSSM systems unless they have been accredited by the NSW Ministry of Health. A certificate of accreditation may include specific requirements for the installation, operation and maintenance of the accredited OSSM system.

The types of OSSM systems to which accreditation apply include septic tanks, collection wells, aerated wastewater treatment systems, aerobic sand and textile filter systems, constructed wetland treatment systems, greywater treatment systems and composting toilets. Further information about OSSM systems and accreditation can be sourced from NSW Ministry of Health [www.health.nsw.gov.au/environment/domesticwastewater/](http://www.health.nsw.gov.au/environment/domesticwastewater/)



## OSSM Designer

The key role of an OSSM designer is to perform site and soil assessments in accordance with AS/NZS 1547 On-site domestic wastewater management, prepare and certify OSSM design reports, is familiar with current OSSM legislation and prepare OSSM operation and maintenance guidelines (Refer to BSC OSSM Strategy - Section 5.2 OSSM Designers for suitably qualified person requirements).

## OSSM Installation Contractor

The OSSM installation contractor must be competent and experienced in construction and installation of OSSM systems, have attended an appropriate accredited training program for installing OSSM systems, consult and liaise with the designer during installation/construction phase to ensure design integrity and certify that the installation has been installed in accordance with the approved design report. (Refer to BSC OSSM Strategy - Section 5.3 OSSM Installation Contractors for suitably qualified person requirements).



## OSSM Service Agent

There are certain OSSM systems that require servicing at regular intervals in accordance with their NSW Ministry of Health Accreditation and/or the OSSM Approval to Operate conditions. These particular OSSM systems are typically Aerated Wastewater Treatment Systems (AWTS), but may also include sand filter systems, constructed wetlands (reed beds), composting toilets, greywater treatment systems and commercial systems.

All service agents who carry out inspections and/or perform maintenance work on OSSM systems must be suitably qualified persons and have appropriate training (refer to BSC OSSM Strategy Section 5.4). Service agents are to provide advice and education to owners and occupiers of OSSM systems in regard to their system operation and maintenance requirements.

Service agents are to produce an inspection report, in triplicate, for each service undertaken. This report is to certify compliance with operating requirements, specify repairs undertaken and results of on-site tests. The service agent is to provide the owner with the original of this report, a copy to BSC and a copy is kept for their own records.

If a service agent observes that an OSSM system failure has been caused by improper use of the system, the service agent is to consult with the owner to ensure preventative actions are undertaken. If the problem continues, then the matter is to be reported to BSC for appropriate action. When there is an identified pollution incident, (eg effluent discharge), the service agent is required to notify BSC.

Service agents are to carry out temporary repairs and to correct any immediate risks to public health and ensure that any residual materials removed from an OSSM system are handled and disposed of in accordance with environmental and public health standards and BSC's requirements standards and BSC's requirements.

# OSSM APPROVAL TO INSTALL, CONSTRUCT, ALTER APPLICATION - REQUIREMENTS

Under Section 68 of the Local Government Act 1993, Council approval is required for the installation, construction or alteration of an OSSM system including the drains connected to the system. Failure to obtain an approval or to comply with the conditions of an approval is an offence, which may result in fines being issued and/or legal action.

The applicant/owner is to engage the services of a suitably qualified person (refer to BSC OSSM Strategy Section 5.0) to prepare an OSSM Design Report to accompany the OSSM approval to install application.

The report and application is to provide all the necessary information, in accordance with Local Government (General) Regulation 2005, to enable BSC to determine the application.

## OSSM Design Report - Key Components

1. **Introduction** – provide property location, description and reason for lodgement of application.
2. **Summary of proposed works** – nominate wastewater volumes, type of OSSM system and calculated effluent land application area size.
3. **Desktop Study** – climate data, drinking water catchment area, priority oyster aquaculture area, soil landscape maps, flooding maps, groundwater bore locations, acid sulfate soils, contours etc.
4. **Site and Soil Evaluation** – inspection date, site features and constraints identified, soil bore hole or test pit results – colour, texture, coarse fragments, structure, soil category, design loading/irrigation rate, pH, soil dispersion test etc.
5. **Setback Distances** – confirm that OSSM facilities comply with recommended setback distances from sensitive receptors, or alternatively justify a lesser setback distance using AS/NZS 1547 – Appendix R Method.

6. **OSSM and Effluent Land Application Area** – state the type of treatment system, maximum wastewater volumes, Equivalent Person (EP) number, calculations, spreadsheets, copy of any OSSM model computations and trench/bed, sand mound or sub-surface irrigation area configurations.
7. **Site Plan** – include property buildings (proposed or existing), boundaries, site features, contours or slope direction, soil landscape information, soil test bore/pit locations, OSSM facility and effluent land application area locations and (scaled) distance measurements.
8. **Operation Manual** – provide NSW Ministry of Health Certificate of Accreditation if applicable, operation and servicing manual and homeowner education material.

## Desktop Study

The first elements to check when intending to install a new or alter an existing OSSM system is the owner and property description details and any existing relevant data that has been recorded for that locale to assist in your analysis of the environment. This research is critical in determining the type of wastewater treatment required and identifying risks with the positioning of the OSSM system in relation to site features.



The desktop study does not negate performing site and soil evaluations, which are needed to cross-check and confirm the desktop study information and fill any data-gaps, but assists in the preliminary assessment of the property for environmental conditions and OSSM suitability.

As a minimum the following desktop study elements are to be researched as part of an OSSM approval to install, construct or alter application and are to be included in the OSSM Design Report.



## Climate Data

Ballina is one of the wettest places in NSW with a distinct seasonal distribution of rainfall. The months between January-March are the wettest and August-October months are generally the driest. Rainfall decreases the further the distance from the coast, as observed when comparing rainfall data between Ballina, Alstonville and Lismore regions. It is also noticeable that there is less rainfall in the southern portion of the shire as depicted in the rainfall data for the town of Broadwater (just south of LGA boundary near Wardell).

**Table 1: Local Regions Annual Rainfall Data**

LOCAL REGIONS	AVERAGE ANNUAL RAINFALL
	BUREAU OF METEOROLOGY BOM (MM/YR)
Ballina – Airport AWS	1843
Alstonville - Tropical Fruit Research Centre	1805
Byron Bay - Cape Byron Lighthouse	1737
Broadwater - Sugar Mill	1493
Lismore - Richmond Hill	1413
Lismore - City Centre	1343

When calculating the size of the effluent land application area, as a minimum, the area must be sized and configured using a monthly water balance. The climate data in Tables 2 and 3 are to be used when formulating a water balance spreadsheet. Select the rainfall data from the nearest town to where the property is located for the inputs into the water balance. **Refer to Appendix A for an example of a monthly water balance spreadsheet.**

**Table 2: Water Balance Climate Data BOM – Mean Rainfall (mm)**

LOCATION	JAN	FEB	MAR	APR	MAY	JUN	JUL	AUG	SEP	OCT	NOV	DEC	ANNUAL AVERAGE
Ballina Airport AWS Site No. 058198	77	92	213	187	162	202	114	86	61	94	122	38	1843
Alstonville Tropical Fruit Site No. 058131	178	225	261	197	182	165	93	75	56	109	133	53	1805
Byron Bay Lighthouse Site No. 058009	165	189	203	189	181	165	107	91	66	108	120	47	1737
Broadwater Sugar Mill Site No. 58065	166	173	189	155	148	129	102	78	54	80	91	16	1493
Lismore Richmond Hill Site No. 058221	201	50	162	40	92	127	56	80	52	83	129	42	1413

**Table 3: Water Balance Climate Data BOM – Pan Evaporation (mm)**

LOCATION	JAN	FEB	MAR	APR	MAY	JUN	JUL	AUG	SEP	OCT	NOV	DEC	ANNUAL AVERAGE
Alstonville (Daily)	5.7	5	4.3	3.5	2.7	2.4	2.7	3.5	4.4	5	5.4	5.9	4.2
Alstonville (Monthly)	177	140	133	105	84	72	84	109	132	155	162	183	1533

## Rous Water and BSC Drinking Water Catchment Areas

If a property is located within a drinking water catchment area, (Rous Water Authority or BSC catchment) then there is a “duty of care” to protect water quality and minimise impacts on waterways in the catchment.

Refer to BSC’s drinking water catchment maps to determine if the property is within a drinking water or public groundwater bore catchment area. Drinking water catchment maps and the Rous Water On-Site Wastewater Management Guidelines are accessible via Council’s website within the OSSM section. BSC’s drinking water catchment map is also accessible on BSC’s website via the Interactive Mapping (Intramaps) portal.



When lodging an OSSM application within the Rous or BSC drinking water catchment areas you must refer to and comply with the “Rous Water On-Site Wastewater Management Guidelines”. If the property is within 250m of a groundwater bore used for public water supply purposes then the “Rous Water On-Site Wastewater Management Guidelines” are also applicable.



BSC Intramaps - Drinking Water Catchment Map (green hatching)



## Rous Water and BSC Drinking Water Catchment Areas (cont)

To comply with the “Rous Water On-Site Wastewater Management Guidelines” the following five steps are to be evaluated and documented within the OSSM Design Report.

1. Identify the pathogen removal capabilities of the proposed OSSM system (refer to Rous Guidelines, section 4.1 – table 2).
2. State the level of risk of pathogens entering a watercourse based on the location of the OSSM system relative to that specific watercourse (refer to Rous Guidelines, section 4.2 – table 4).
3. Select the appropriate table from Appendix A within the Rous Guidelines that is to be used for assessment; based on the location of the OSSM system relative to a water course and the type of vegetation between the OSSM system and a water course.
4. State the suitability of the OSSM system and likelihood of approval, which is based on assessing the combined pathogen risk, treatment train and pathogen removal capacity of the system (refer to Rous Guidelines, Appendix A).
5. Based on the “Suitability” rating, confirm if the application needs to be referred to Rous Water (refer to Rous Guidelines section 5.3, table 5).



Image: North Emigrant Creek

## Priority Oyster Aquaculture Areas

The NSW Oyster Industry Sustainable Aquaculture Strategy states: “Bacteria, viruses, marine biotoxins and environmental pollutants may all impact on the suitability of oysters for human consumption. Most are a direct result of human activity with the exception of marine biotoxins.

Sources that may pose a risk to food safety include:

- sewerage system and septic tank overflows and leaks
- sewage discharges from vessels
- re-suspension of contaminated sediments
- stormwater run-off
- discharges from industrial premises or agriculture.”

If you are intending to upgrade or install a new OSSM system and the system is in close proximity to the Richmond River or tributary stream, then you must determine if the property is within the Priority Oyster Aquaculture Area zone of influence.

Refer to the Priority Oyster Aquaculture Area (POAA) map for the Richmond River to determine the location of Priority Oyster Aquaculture Areas on Council’s website [ballina.nsw.gov.au](http://ballina.nsw.gov.au) (search Priority Oyster Aquaculture Areas)



If the property is located within 100m of the riverbank or tributary and within 10km upstream or downstream (measured along the river) to the nearest Priority Oyster Aquaculture Area then the OSSM installation is within the zone of influence.



BSC Intramaps – Priority Oyster Aquaculture Area Map (purple rectangle zones on river)

## Priority Oyster Aquaculture Areas (cont)

To ensure that there are no impacts on the Priority Oyster Aquaculture Areas when assessing Development and OSSM applications BSC will refer the application, where applicable, to Department of Primary Industries – Fisheries for comment and conditions. The main risks to oyster aquaculture farming from OSSM systems are bacteria and viruses. Key considerations to minimise the risk to oyster aquaculture farming are providing OSSM disinfection, the sub-surface application of effluent and installation above the 1:50 Average Recurrence Interval (ARI) flood level.

### “NSW Oyster Industry Sustainable Aquaculture Strategy - Recommended Actions:

- Sewerage management authorities prepare and implement an On-site Sewerage Management Strategy that includes classifying systems in close proximity to Priority Oyster Aquaculture Areas (POAA) as high risk with annual compliance inspection
- The preferred on-site sewerage management system for sites close to POAA is secondary treatment (aerated wastewater treatment system) with disinfection, subsurface irrigation and a minimum buffer of 100 m to a water body or drain. In circumstances where these requirements cannot be met then additional risk management measures should be incorporated in the design
- Sewer systems improved, maintained and operated so that overflows do not occur as a result of maintenance or operational failure, overflows in dry weather are eliminated or occur only under exceptional circumstances and wet weather overflows are minimised
- Identification of priority urban storm water drains and installation of suitable treatment systems
- Priority treatment drains would include those with a catchment from large hard stand car parks and roadway car parks, caravan parks, golf links, subdivision, commercial/business and shopping centres and industrial areas
- At source control of stormwater for new developments to reduce stormwater impacts.

### Members of the community have a general responsibility to:

- have their on-site sewerage management system approved by the local Council and to operate it in accordance with that approval
- understand how to use their on-site sewerage management system and to make sure regular maintenance inspections are conducted by suitably qualified and experienced technicians
- quickly have their on-site sewerage management system repaired if it fails and report any discharge of effluent to the local Council
- report any pollution incidents to the NSW EPA Environment Line 131555
- remove stock access to the riparian zone adjacent to oyster harvest areas
- ensure that stormwater run-off is not contaminated with chemicals, animal effluent or manure
- use pump-out systems and ensure that no effluent, rubbish or waste goes from your boat to the waterway
- participate in community programs that build resilience in the natural environment and help improve water quality.”

The OSSM designer can obtain further information from the NSW Department of Primary Industries – Fishing and Aquaculture website and also to access the NSW Oyster Industry Sustainable Aquaculture Strategy and Priority Oyster Aquaculture Area Maps.

BSC have developed the following facts sheets to assist OSSM designers and are accessible on BSC’s website:

**Fact Sheet 11** - Priority Oyster Aquaculture Area  
**Fact Sheet 12** - NSW Oyster Industry Sustainable Aquaculture Strategy - Extracts



## Soil Landscape Maps

To obtain desktop information in regard to the geology and soils of the BSC LGA refer to the Soil Landscapes of the Lismore-Ballina 1:100,000 Sheet (9540-9640) – Map and Report. This publication can be purchased via the NSW Government – Office of Environment and Heritage website.

The soil landscape groups of BSC LGA are accessible on BSC’s website via the Interactive Mapping (Intramaps) portal. However you will still need to refer to the Lismore-Ballina Report to understand the soil landscape characteristics and constraints. Contact BSC for assistance in accessing or using the Intramaps website portal.



### BSC Intramaps – Soil Landscape Map

Name of order	Derivation	Connotation
Anthrosols	Gr. <i>anthropos</i> , man	'human-made' soils
Calcarosols	L. <i>calcis</i> , lime	calcareous throughout
Chromosols	Gr. <i>chroma</i> , colour	often bright coloured
Dermosols	L. <i>dermis</i> , skin	often with clay skins on ped faces
Ferrosols	L. <i>ferrum</i> , iron	high iron content
Hydrosols	Gr. <i>hydor</i> , water	wet soils
Kandosols	Kandite (1:1) clay minerals	-
Kurosols	-	pertaining to clay increase
Organosols	-	dominantly organic materials
Podosols	Rus. <i>pod</i> , under; <i>zola</i> , ash	podzols
Rudosols	L. <i>rudimentum</i> , a beginning	rudimentary soil development
Sodosols	-	influenced by sodium
Tenosols	L. <i>tenuis</i> , weak, slight	weak soil development
Vertosols	L. <i>vertere</i> , to turn	shrink-swell clays

14 Australian soil orders - name source (ie greek, latin) and associated meanings





## Groundwater Bores

The NSW Department of Primary Industries – Office of Water website provides groundwater bore data and maps to check the location of the nearest licensed groundwater bore in proximity to your property.

Steps to access information on website (<http://allwaterdata.water.nsw.gov.au/water.stm>):

- Access the data via expanding “All Groundwater Map”, expand “North Coast Region”
- Click on “Richmond River Basin”
- Keep zooming in until you can view your property and find the nearest Ground Water (GW) Bore Data
- Click on the bore to access bore driller’s information, ie water bearing zone depth.

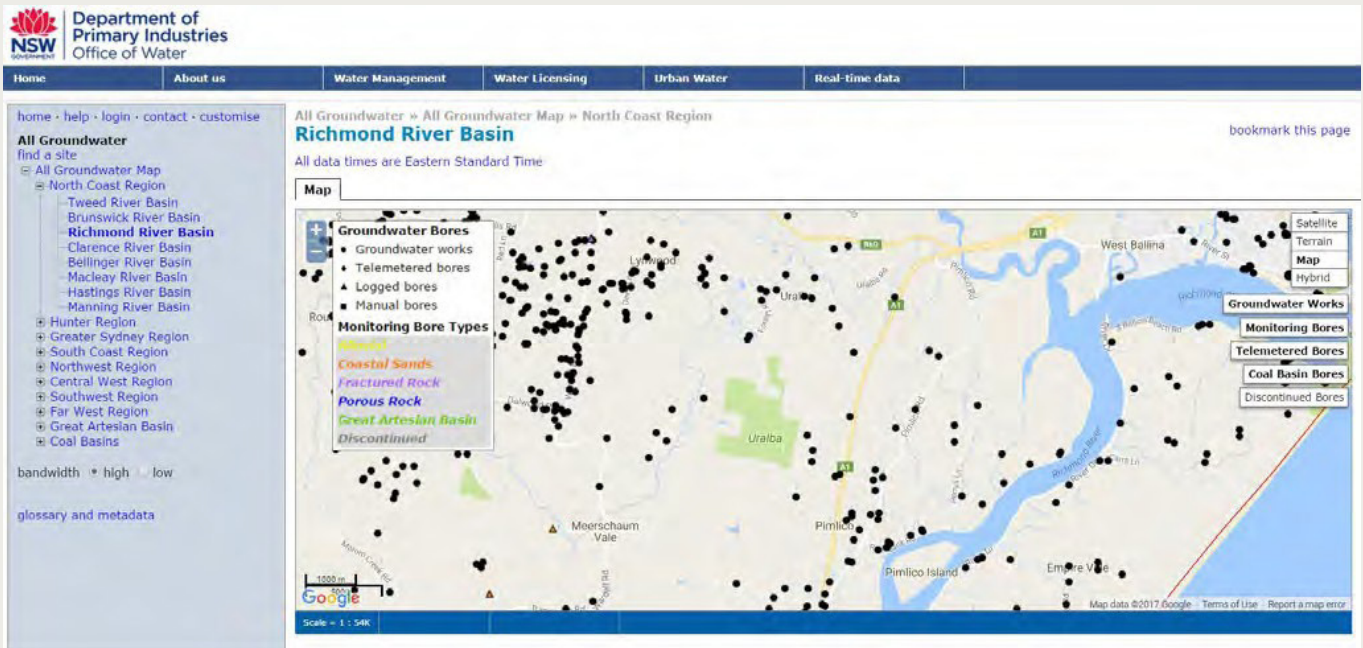

### Groundwater bore map and information

## OSSM and Flood Level Requirements

The flooding potential of the property must be determined, in regard to the installation of the OSSM system, especially for low-lying flood plain areas of the BSC LGA. The OSSM tank lid, electric and effluent land application area (ie bottom of ETA bed or sub-surface irrigation trench or distribution bed within sand mound) is to be above the 1:50<sub>2050</sub> ARI flood level.

BSC has flood data for 1:50 & 1:100 year ARI for the projected 2050 year and 2100 year.

This information is accessible on BSC’s website via the Interactive Mapping (Intramaps) portal. If there is no Permanent Survey Mark or Australian Height Datum (AHD) mark on-site or adjacent to the subject property then the owner will need to engage a surveyor to ascertain the ground surface level.

Once the ground surface level height (AHD) has been determined then cross check against the BSC 1:50 year ARI flood level height data. This information will assist in determining the method of applying effluent to the land and installation configuration.

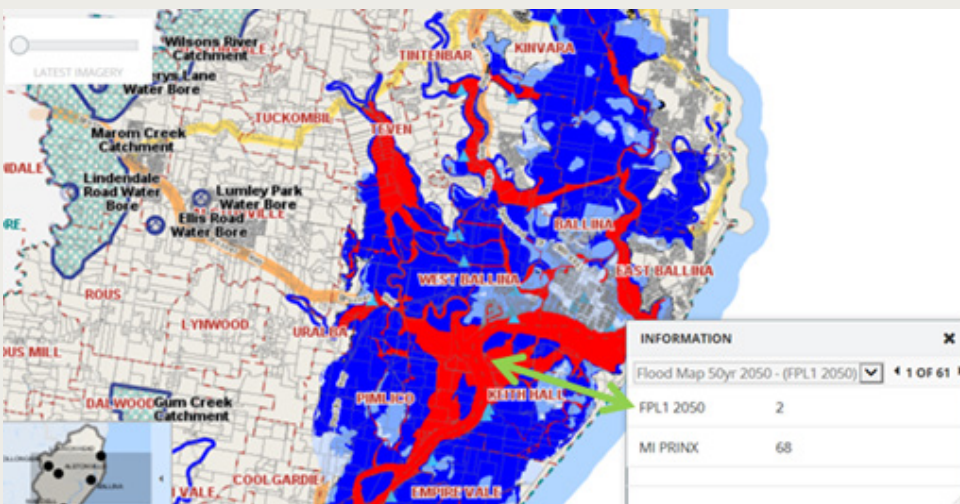

## Acid Sulfate Soils

Acid sulfate soils are generally found in soil layers on the floodplain at various depths below the surface. Their exposure to the air can result in the production of sulfuric acid, which can reduce the agricultural productivity of land, cause environmental damage to aquatic ecosystems and damage infrastructure. Development consent may be required for works (including OSSM installations) within areas identified as having the potential for acid sulfate soils, dependent on the proposed work, excavation volumes and the risk class of the land.

### The key elements:

- Check BSC acid sulfate soil maps (available on BSC website, see example on next page)
- Determine if the property is within an acid sulfate soil zone, if yes, state the risk class for that land (ie 1-5) and whether the proposed works will penetrate into the acid sulfate soil layers or result in the lowering of the watertable to within these layers
- Confirm extent of proposed works, ie excavation depth, volume of excavation, time period that excavation hole will be exposed, management of soil stockpile and if any soil is to be transported off-site. If desk top assessment or site indicators

suggest acid sulfate soil materials will be disturbed, laboratory analysis should be undertaken to determine whether acid sulfate soils are present or absent, to delineate the lateral and vertical extent, and to quantify the maximum Net Acidity requiring management if disturbed

- Provide a management plan within the OSSM Design Report detailing the acid sulfate soil monitoring method and testing procedure (ie field pH tests and soil laboratory analysis), preventive actions, containment of soil stockpiles, transportation method and amelioration application rates (ie lime)
- For further acid sulfate soil guidance refer to: *Ahern C R, Stone, Y, and Blunden B (1998). Acid Sulfate Soils Assessment Guidelines, Acid Sulfate Soil Management Advisory Committee: Wollongbar, Australia.* *Sullivan, LA, Ward, NJ, Toppler, NR & Lancaster, G 2017, National acid sulfate soils sampling and identification methods manual, Department of Agriculture and Water Resources: Canberra, Australia.*



It is not envisaged that domestic OSSM installations will require an acid sulfate soil management plan. However, an acid sulfate soil management plan maybe required for drainage works and commercial OSSM sized systems, low pressure sewer installations or when connecting a cluster of non-sewered properties into Council's reticulated sewerage system.

Sites should be investigated for acid sulfate soil materials if there is any evidence that reasonably suggests that acid sulfate soil materials may be present in the vicinity and that these materials may be disturbed.

Examples, of such evidence may include any of the following:

- soil or sediment disturbance of 100m<sup>3</sup> or more located within an area mapped with at least a moderate risk of acid sulfate soil materials occurring within 3 m of the natural soil surface
- soil or sediment disturbance of 100m<sup>3</sup> or more, with excavation likely from below the natural watertable, in an area with at least a moderate risk of acid sulfate soil materials occurring within 3m of the natural soil surface, or with at least a moderate risk of acid sulfate soil materials occurring deeper than 3m of the natural soil surface
- temporary or permanent lowering of the watertable in areas mapped with a risk of acid sulfate soil materials occurring within 3m of the natural soil surface (e.g. for groundwater abstraction, dewatering, installation of new drainage, modification to existing drainage).



**BSC - Acid Sulfate Soil Map**

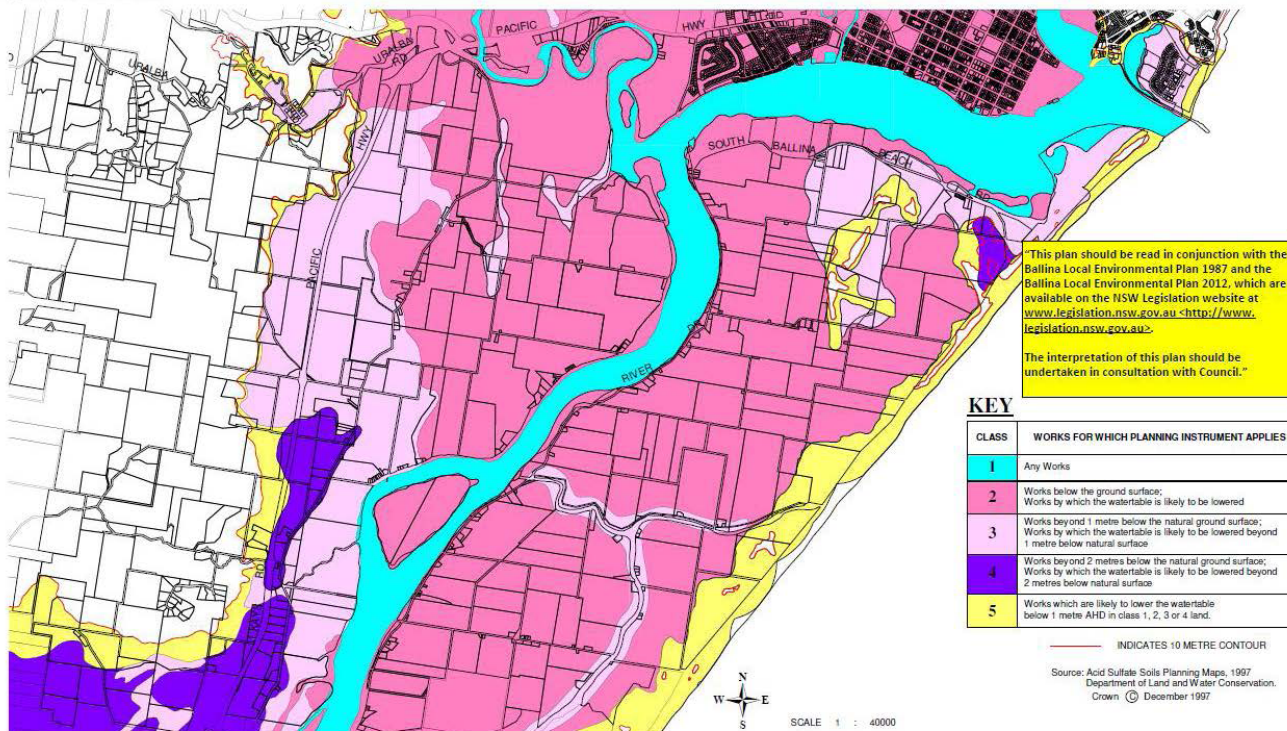

**Site and Soil Evaluation**

The site and soil evaluation of a property is to follow a systematic and staged process. The extent of assessment required is determined by the initial desktop study results, availability of data, size of development, local constraints for OSSM systems, and potential public and environmental risk.

**Site Assessment Factors**

Refer to AS/NZS 1547: On-site domestic wastewater management – Appendix D –Table D1.

**Soil Assessment**

Refer to AS/NZS 1547 – Appendix B - B4 Soil Assessment, Appendix C – Site and Soil Evaluation for Planning, Rezoning and Subdivision of Land, and Appendix D - Site and Soil Evaluation for Individual Lots.

To adopt a conservative soil evaluation procedure a minimum of three confirmatory soil observations is required within the proposed effluent land application area, ie one test pit (in centre of area) and two boreholes (one bore hole near where the effluent enters the area and one bore hole at the far end of the area).

When faced with poor soils or challenging sites it is recommended that a soil permeability constant head test be performed and/or the soil sample be sent to a soil testing laboratory for analysis and classification.



A soil permeability constant head test will assist in determining the indicative permeability (Ksat) of the soil and soil category. Refer to AS/NZS 1547 - Appendix G for details on how to perform this test method.



**Soil Colour**

Refer to AS/NZS 1547: On-site domestic wastewater management – Appendix E- E3. Also refer to BSC Soil Fact Sheet 3 – Soil Colour.

**Soil Texture**

Refer to AS/NZS 1547: On-site domestic wastewater management – Appendix E- E4 and Table E1. Also refer to BSC Soil Fact Sheet 2a – Soil Texture & Soil Fact Sheet 2b – Soil Texture.

**Soil Assessment of Coarse Fragments**

Refer to AS/NZS 1547: On-site domestic wastewater management – Appendix E- E5 and Tables E2 & E3.

**Soil Structure**

Refer to AS/NZS 1547: On-site domestic wastewater management – Appendix E- E6 and Table E4. Also refer to BSC Soil Fact Sheet 1 – Soil Structure.

**Determine Soil Category**

Refer to AS/NZS 1547: On-site domestic wastewater management – Section 5 and Table 5.1. If the OSSM designer (soil evaluator) has doubt in determining the soil category then it is recommended that a sample of soil is taken from the soil bore hole to a soil laboratory for analysis and classification (It is critical to describe the soil characteristics and confirm the hydraulic conductivity of any limiting layer within 600mm of the point of effluent application).

**Recommended Design Loading Rates or Design Irrigation Rates**

Refer to AS/NZS 1547: On-site domestic wastewater management – Section 5 and Table 5.2.

**pH of Soil**

The pH of a soil can alter the availability of nutrient elements for plant uptake and can cause metal toxicities if pH is too low or too high. Acid soils tend to be leached of major plant nutrients, for example calcium, magnesium, nitrogen and possibly molybdenum, while phosphorous may not be present in plant-available form. Alkaline soils are often deficient in iron, manganese, copper or zinc (Morand, 1994).

An on-site soil pH test is to be performed, using a calibrated instrument or colour-test-strips, to determine the soil acidity/alkalinity. A soil pH reading between 6.5 and 8.0 is ideal for plant uptake of phosphorous, potassium and nitrogen. For strong acidic soils specialist’s advice (soil laboratory test) should be sought in regard to chemical additives (eg lime) and ameliora application rates.

**Table 4: pH Soil Test Results**

ACIDITY - pH	(Extreme) < 4.5	(Very Strong) 4.5—5.0	(Strong) 5.1—5.5	(Moderate) 5.6—6.0	(Slight) 6.1—6.5
ALKALINITY - pH	(Very Strong) > 9.0	(Strong) 9.0—8.5	(Moderate) 8.4—7.9	(Slight) 7.8—7.4	(Neutral) 7.3—6.6

**pH of Wastewater**

The acidity or alkalinity of wastewater affects the treatment process and the environment. Low pH indicates elevated acidity; while a high pH reading indicates alkalinity (a pH of 7 is neutral). The pH of wastewater needs to remain between 6 and 9 to protect organisms involved in the treatment process. Acids and other substances that alter pH (eg from industrial or commercial sources) can inactivate and be detrimental to the wastewater treatment processes.

**Soil Dispersion Test Method for Wastewater**  
 Information and extracts from Lanfax Laboratories technical paper - Armidale 10 April 2015 - Emerson Aggregate Stability Test for Wastewater



**Note:** The soil dispersion test method in this document is based on the Emerson Aggregate Test (EAT), not the Modified Emerson Aggregate Test (MEAT) mentioned in AS/NZS 1547: On-site domestic wastewater management.

The structural stability of soil peds and how they behave when effluent is applied is essential to determining soil classification and the type, size and configuration of an effluent land application area.

The pathway of effluent movement through the soil profile (drainage) and its reaction with soil colloids and miniscule pores (air voids) may lead to a condition called dispersion. Dispersion of soil colloids has the potential to block these pores in the soil and reduce hydraulic conductivity (permeability).

The slaking (collapsing) of a soil ped is mostly due to low organic matter and is not considered a detriment to effective effluent dispersal, but may lead to some temporary hard setting (crust) on ground surface.

**Test Method**

The modified Emerson soil dispersion test method requires 3-5 air-dry soil peds of about 5 mm (taken from soil bore hole) to be immersed in a solution having Sodium Adsorption Ratio (SAR) 5 and EC approx. 1 dS/m to mimic domestic effluent (Patterson, 1994). The synthetic effluent test solution is obtainable from Soil Testing Laboratories along with suitable trays to insert soil peds so you can observe any dispersion, or alternatively the soil laboratory can perform the soil dispersion test and provide results. The soil peds are examined after two hours and the appearance of the peds is compared with Figure 1 (see below). There is no requirement to remould the soil bolus if a no dispersion result is achieved.



Rainwater or deionised water is not appropriate for the soil dispersion test solution as it does not represent effluent characteristics and may give a misleading result

**Figure 1: Soil Dispersion Test - Possible Results**



If the soil dispersion test result indicates a dispersive soil then the soil is to be classed as a Category 6 soil (Medium to Heavy Clay Table 5.1 Determination of Soil Category AS/NZS 1547) and the effluent land application area is to be designed for conservative design loading rates. Specialist advice (ie soil laboratory) should be obtained to improve the soil, determine soil ameliora application rates and techniques to apply a mineral substance (eg gypsum).

## Modified Aggregate Stability Test for On-Site Wastewater Assessment

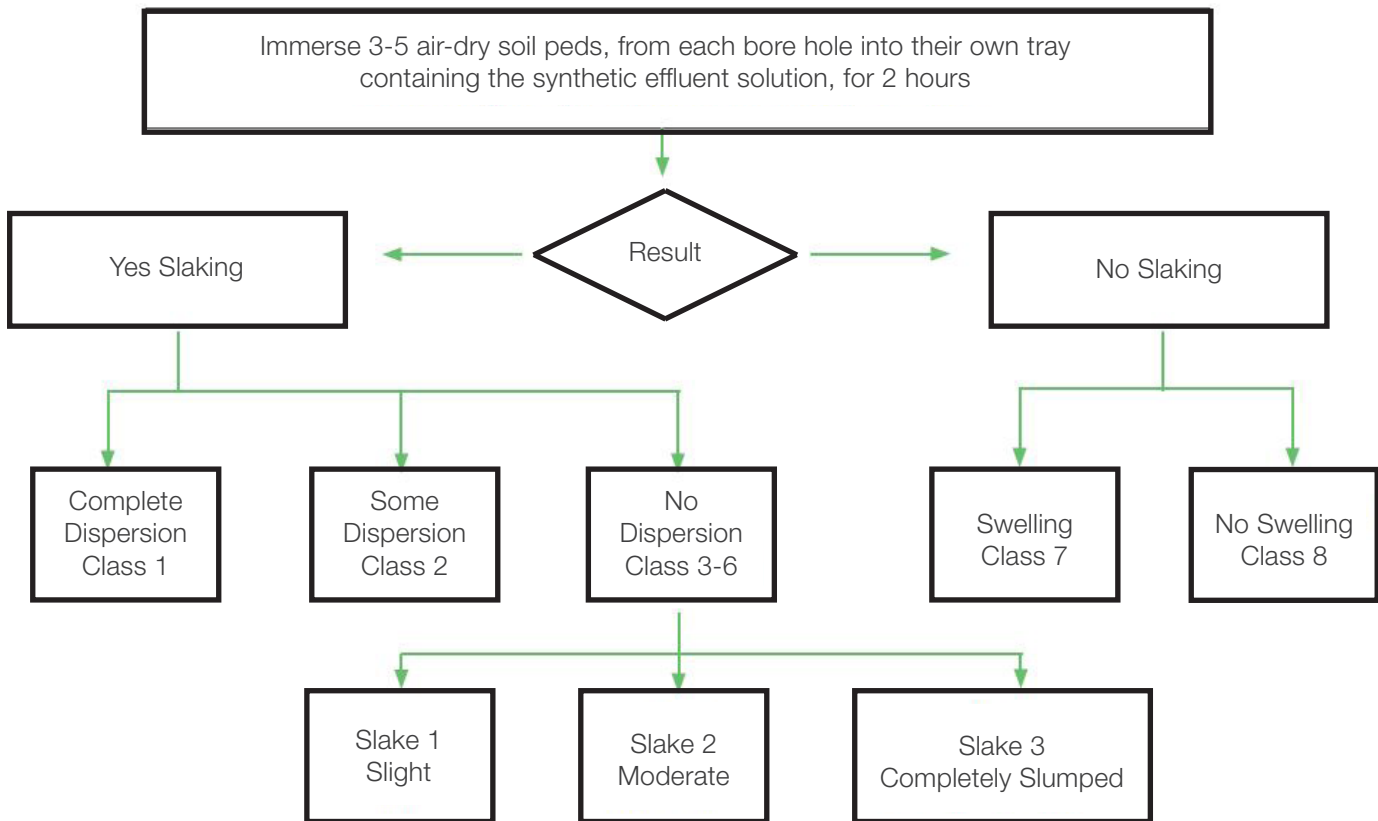

### Reporting Modified Emerson Test Results

The modified Emerson test can be reported and interpreted, with respect to domestic wastewater application as:

**Class 1** – severe dispersion, maybe related to high sodicity which forces the clay particles apart in water. Amelioration with lime or gypsum may improve structural stability by increasing electrical conductivity (EC). Class 1 soils have a major limitation to wastewater application because of reduced permeability and potential to compact as the pores block.

**Class 2** – moderate dispersion, maybe related to high sodicity. Amelioration may be effective by increasing EC. Without amelioration, this class has a major limitation to wastewater application as for Class 1.

**Classes 3-6** – the remoulding, and 1:5 soil:water suspension tests are not required for wastewater assessment. Test results are reported by noting the degree of slaking as:

Slake 1 (slight), slake 2 (moderate) or slake 3 (completely slumped) (as shown in Figure 1). Slake 1, 2 or 3 – no limitation to wastewater application, but may benefit from additional organic matter for surface irrigated soils.

As a shorthand, this category of slaking soils may be reported as \*3/6, slake 1 indicating that the class may be within the group of classes 3 to 6, but the general behaviour of the ped in the synthetic effluent (SAR 5, EC 1 dS/m) is that the ped slakes slightly. Replace slaking with grade 2 or 3 as appropriate.

**Classes 7 and 8** – these soils are water stable, but may swell (Class 7) or retain original size and shape (Class 8). Neither of these classes is a limitation to wastewater application.

## Recommended Setback Distances for Effluent Land Application Areas

### Non-drinking water catchment areas

The OSSM designer is to refer to AS/NZS 1547 – Appendix R, Table R1 - Recommended Setback Distances for Land Application Systems – Guidelines for Horizontal and Vertical Setback Distances.

There are two acceptable methods to comply with horizontal and vertical setback distances from OSSM systems and effluent land application areas to site features.

1. Adopt the maximum setback distances nominated in AS/NZS 1547 Table R1 – Guidelines for Horizontal and Vertical Setback Distances where the site/system features are on the high end of the constraint scale (ie less wastewater treatment and the more risks on site will correspond to greater separation distances). If the site assessment and OSSM Design Report adopts and confirms compliance with the maximum setback distances (or greater) then no additional information is required;

Alternatively, if the maximum separation distances from an OSSM system and effluent land application area to site features cannot be complied with then Option 2 is required.

2. Use the method in AS/NZS 1547 – Appendix R – Recommended Setback Distances for Land Application Systems to determine and justify the reduced setback distance to site features. Refer to BSC OSSM Fact Sheet 13 for a guide on how to use this setback method and the information that is to be included in the OSSM report.



It is recommended, when compliance with maximum separation distances from a watercourse or groundwater bore cannot be achieved, that the OSSM designer uses and includes in their OSSM Design Report “AN IMPROVED VIRAL DIE-OFF METHOD FOR ESTIMATING SETBACK DISTANCES – (WC Cromer, E A Gardner and P D Beavers). The separation distance determined from using AS/NZS 1547 – Appendix R method is further supported or increased based on the viral die-off result.

Refer to Appendix A and B for an example of how to use the AN IMPROVED VIRAL DIE-OFF METHOD FOR ESTIMATING SETBACK DISTANCES.

# SIZING OF OSSM SYSTEMS

## Calculating Wastewater Volumes and Equivalent Population (EP)

Refer to AS/NZS 1547: On-site domestic wastewater management – Appendix H –Table H1 for typical domestic wastewater design flow allowances. If the property is used for non-domestic purposes then refer to other appropriate wastewater technical documents to support the wastewater design flow allowance and/ or provide site specific data ie water meter reading results.

It is standard practice in the wastewater industry, for domestic properties, to determine the EP rating based on the bedroom count. There are two common methods used and acceptable to BSC.

1. Total number of bedrooms + safety factor of one eg 4 bedrooms + 1 (safety factor) = 5EP; or
2. Total number of bedrooms x 1.5EP eg 4 bedrooms x 1.5EP = 6EP (more conservative method).



If the dwelling floor plan nominates a study, office or rumpus room then this room is to be included in the EP calculations as these type of rooms can easily be converted into an additional bedroom and therefore potentially increasing the wastewater volume and size of the OSSM system.

### Domestic OSSM Systems and Capacities:

This section is applicable for OSSM tanks and vessels that receive wastewater generated from domestic premises of quantities of no greater than 10 Equivalent Persons (EP) or 2,000 litres/day. There has been no allowance, in sizing the tanks and vessels, to receive waste from spa baths and/or garbage grinders and their use in non-sewered areas is not recommended.

### Septic Tanks

All septic tanks, septic closets and Common Effluent Drainage (CED) pre-treatment tanks must comply with and have obtained a Certificate of Accreditation issued by the NSW Ministry of Health, and be sized

as a minimum, in accordance with the NSW Ministry of Health - Sewage Management Facility Vessel Accreditation Guideline.

It is also recommended that you refer to AS/NZS 1546.1: On-site domestic wastewater treatment units – Part 1 Septic Tanks for performance, design and sizing criteria. AS/NZS 1547: On-site domestic wastewater management also provides guidance for sizing septic tank capacities.

**Table 5: Allowances and Daily Flows (DF) for Calculation of Tank Capacities**

WASTE	CALCULATION ALLOWANCE
S (Sludge Allowance)	1550 Litres
WC (Water Closet)	50 DF Litres/person/day
HB (Handbasin)	10 DF Litres/person/day
K (Kitchen)	10 DF Litres/person/day
B + SHR (Bath and Shower)	50 DF Litres/person/day
L (Laundry)	30 DF Litres/person/day
All wastes (WC + HB + K + B + SHR + L)	150 DF Litres/person/day





The general formula used to calculate the septic tank capacity is  $S + (DF \times N) = \text{Capacity (litres)}$

S = Sludge allowance

DF = Daily flow

N = Number of persons (Equivalent Persons EP)

**Example:** Three bedroom dwelling (3 bedrooms x 1.5 EP/bed = 4.5 EP), however a septic tank is to be designed on a minimum of 5 persons using the facility.

SLUDGE ALLOWANCE	DAILY FLOW OF X NUMBER OF PERSONS EP	MIN TANK CAPACITY
1550 litres	150 L/person x 5EP = 750	2300 litres

Therefore the standard off the shelf manufactured septic tank, to be installed for this example is 3000 litres, which is consistent with AS/ NZS 1546.1.



The recommended desludging interval for a standard domestic septic tank should be every 3-5 years, however it is preferred that the septic tank is inspected on a regular basis to monitor sludge levels.

**Aerated Wastewater Treatment System and Sand Filter System**

A sewage management facility (incorporating aerated wastewater treatment and sand filter systems) must comply with and have obtained a Certificate of Accreditation issued by the NSW Ministry of Health and be in accordance with the NSW Ministry of Health - Sewage Treatment Accreditation Guideline.

It is also a requirement that you refer to AS/ NZS 1546.3: Secondary Treatment Systems for performance, design, sizing and testing criteria. A minimum wastewater daily flow of 150 litres/person is to be used in calculating the size of AWTSSs.

Specialist advice is to be sought in the design of sand filter systems and only experienced and qualified OSSM designers are to be engaged to prepare design reports for these types of systems.

**Domestic Greywater Treatment Systems**

A Domestic Greywater Treatment System must comply with and have obtained a Certificate of Accreditation issued by the NSW Ministry of Health and be in accordance with the NSW Ministry of Health – Domestic Greywater Treatment Systems Accreditation Guideline.

It is also a requirement that you refer to AS/NZS 1546.4: Domestic Greywater Treatment Systems for performance, design, sizing and testing criteria.

**Waterless Composting Toilets**

A Waterless Composting Toilet must comply with and have obtained a Certificate of Accreditation issued by the NSW Ministry of Health and be in accordance with the NSW Ministry of Health – Waterless Composting Toilet Accreditation Guideline.

It is also a requirement that you refer to AS/NZS 1546.2: Waterless Composting Toilets, for performance, design, sizing, marking and testing criteria.

**Constructed Wetlands/Reed Beds**

A reed bed is typically a rectangular or round concrete or poly tank, filled with gravel and planted with macrophytes such as reeds and rushes. Wastewater passes through the root zone of the reeds where it undergoes treatment via physical, chemical and biological interactions between the wastewater, plants, micro-organisms, gravel and atmosphere. The reed beds inlet and outlet pipes are positioned below the gravel surface, so that the water always remains below the surface, thus minimising the risk of human contact with the wastewater, mosquito breeding and unpleasant odours.

A reed bed installation is classed as a secondary wastewater treatment system and is installed downstream of a primary treatment septic tank. By improving the quality of treated wastewater (effluent) the size of the effluent land application area can be reduced. It is also considered an added measure when confronted with site constraints ie poor soils and reduced setback distances.

For a reed bed to be considered to produce secondary effluent quality, the reed bed must be sized to achieve a minimum 5-7 day residence time (the time that it takes for wastewater to travel through the reed beds, from entry to exit to enable sufficient treatment).

The size of aggregate for reed bed installations is important and is to be appropriate to prevent clogging of the system. For example large aggregate is to surround the inlet and outlet pipework ie 50-100mm and smaller aggregate ie 20mm for the main section of the reed bed.

**Sizing Reed Beds**

The reed bed residence time is determined by the water holding capacity of the reed bed, which is governed by the water depth, reed bed surface area and porosity of the gravel used. Three sizing methods will be acceptable to BSC.

1. Coarse sizing method -  $4\text{m}^2$  (surface area) per person to achieve a residency time of 7 days for a 5 person household (ie  $4\text{m}^2 \times 5 \text{ EP} = 20\text{m}^2$  reed bed surface area). This is based on a minimum reed bed water depth of 0.5m.

2. Calculation Formula - Residence time (days) = Reed Bed Volume (litres) x Porosity (dimensionless – fraction or %) / Daily Wastewater Generation (litres).

**Example:**

- Daily wastewater generated from 4 bedroom dwelling (5EP) = 750 litres (5EP x 150litres/EP/day).
- The reed bed volume - 3m long x 2.4m wide x 0.5m deep =  $3.6\text{m}^3$ /reed bed. Due to the high daily wastewater volume generated, multiple reed beds in series will need to be installed to achieve the required 5-7 day residence time.

Proposal is to install four reed beds ie  $3.6\text{m}^3 \times 4 = 14.4 \text{ m}^3$

Porosity aggregate = 0.4 (ie gravel 0.25-0.4, sand 0.25-0.5, silt 0.35-0.5, clay 0.4-0.7)

Residence time =  $14,400 \text{ litres } (14.4 \text{ m}^3) \times 0.4 / 750 \text{ litres}$

Residence time =  $5760 / 750$

Residence time = 7.7 days (complies with 5-7 day residence time)

3. OSSM Computer Modelling ie It is acceptable to use Lismore City Council or Byron Shire Council or equivalent OSSM Modelling Programs that provide OSSM computations supporting the number and size of reed beds



The reed bed structure must be made of a strong durable material eg concrete, poly or equivalent. The use of a liner membrane material for the reed bed construction is not permitted within BSC LGA.

**Photo of Reed Bed Installation**



For further details on reed bed design, maintenance and educational information refer to Lismore City Council's document titled – "The Use of Reed Beds for the Treatment of Sewage & Wastewater from Domestic Households".

**Wastewater Collection Well**

A wastewater collection well is to comply with NSW Ministry of Health - Sewage Management Facility Vessel Accreditation Guideline.

The collection well capacity is to be determined by the daily flow/person (DF) multiplied by the number persons (N) to calculate one day's storage volume. Confirm and provide details if the wastewater is to be

pumped to an effluent land application area, reticulated sewerage system, forms part of a common effluent drainage system, the number of pumps used or if the wastewater to be transported off site via tanker pump out.

**Table 6: Wastewater Collection Well Capacities**

COLLECTION WELL USE	SINGLE PUMP	DUAL PUMP	TANKER PUMP OUT
Capacity Calculation	DF x N x 2 (2 days of storage)	DF x N (1 day of storage)	DF x N x 7 (7 days of storage)
Minimum Capacity	2050 litres	2050 litres	5250 litres

For collection wells that have pump/s installed they must also be fitted with a non-return valve on the pump outlet pressure pipework. All collection wells are to be fitted with a high level audio and visual alarm.

**Sewage Ejection Pump Station**

A sewage ejection pump station macerates and pumps sewage to a small diameter sewerage reticulated system. A sewage ejection pump station is to comply with the NSW Ministry of Health - Sewage Management Facility Vessel Accreditation Guideline.

The minimum capacity of the sewage ejection pump station is to equate to six hours of the average wastewater peak flow measured over an eight hour period per day. A wastewater daily flow of 150 litres/person/day is used in this calculation.

Example:

A four bedroom residential dwelling (6 EP) generates 900 litres of wastewater/day (6 EP x 150 daily flow = 900). The average peak wastewater flow over an eight hour period is approximately 113 litres/hour (900/8hrs = 112.5). Therefore the minimum operation capacity of the sewage ejection pump station, for a four bedroom dwelling is 678 litres (113 x 6hrs = 678).

The sewage ejection pump station must be fitted with a non-return valve on the pump outlet pressure pipework and fitted with a high level audio and visual alarm.

**High Level Alarms**

All OSSM installations that incorporate a pump must have a high level alarm installed eg audio and visual alarm positioned either on the top of OSSM tank or fastened against a permanent structure where it will be observed during normal daily trafficable flow paths. There is to be an additional minimum of 24 hour wastewater storage capacity, within the OSSM tank above the high level alarm cut in point, to allow sufficient buffer and time for a service person to attend to a failing system.

**Hydrostatic Lift – Floatation Prevention**

All OSSM tanks proposed to be installed in the BSC LGA subject to high groundwater and/or flooding must be designed and installed in accordance with manufacturers requirements and to prevent hydrostatic lift ie avoid the tank from floating when the tank is empty or pumped out.

Commercial OSSM systems must be designed, installed to prevent hydrostatic lift and certified by a Wastewater Consultant or Professional Engineer.

**OSSM Commercial Systems**

OSSM systems with capacities above 10 EP and less than 2,500 EP are classified by BSC as commercial OSSM systems. If proposing to install a commercial OSSM system then the following assessment steps and information is to be included in the OSSM Approval to Install Application (OSSM Design Report).

- Conduct a desktop study, refer to soil maps, drinking water catchment maps, Rous Water On-Site Wastewater Management Guidelines, Ballina Shire Council's On-Site Sewage & Wastewater Management Strategy, soil stability and climate data etc. Ensure documents are referenced if applicable
- Determine the effluent quality required to achieve development objectives (ie reuse or landscape sub-surface irrigation). Effluent quality is to be based on several factors eg the intended end use of the effluent, method of applying the effluent to the land, is recycled water used for particular plumbing fixtures, site constraints, receiving environment, sensitive area (oyster aquaculture farming), drinking water catchment area, high groundwater table, soil types, slope, separation distance from registered groundwater bore location, drinking water supply source, buffers from site features etc. State how you determined the level of effluent quality needed for the development and provide supporting information/documentation (eg risk assessment method)
- Nominate the type of OSSM system that can treat the maximum quantity and quality of wastewater generated and achieve the effluent standard required
- Provide documentation (ie wastewater loading certificate) to support that the nominated OSSM system can treat the wastewater volumes generated and achieve the effluent quality standard required eg include any state government (or equivalent) certificate of accreditation, standards and/or water marks for manufactured components. Design certification is required from a Wastewater Consultant or registered Professional Engineer. The applicant/owner may be required to conduct an in-situ effluent quality validation and verification accreditation monitoring program (eg refer to Part 7 of NSW Guidelines for Management of Private Recycled Water Schemes, for guidance on this process)

- Conduct an appropriate site and soil evaluation on the property. The assessments are to be in accordance with AS/NZS 1547: On-site domestic wastewater management or other suitable equivalent technical standards
- Calculate the size of the effluent land application area required. Include water and nutrient balance model/spreadsheet/calculations and select the most limiting sized area (ie largest area). Detail how the effluent is to be applied evenly to the land. Provide irrigation design and pump calculations, details of flush points and nominate all effluent irrigation areas and reserve areas if applicable
- Site plan indicating the location of all OSSM system and effluent land application facilities and setback distances from site features
- Include any other documentation ie photos, reports, previous approvals, technical documents that will support your application
- A Wastewater Consultant or registered Professional Engineer is to provide certification of the OSSM system at design, installation and commissioning stages
- Operation and maintenance management plan is to be developed. Provide an OSSM treatment train process flow chart and nominate all critical control points in the process that will need to be monitored. Include details on:
  - *What is to be monitored*
  - *How it is to be monitored*
  - *When is it to be monitored*
  - *Who is to monitor*
- Include education information that details how the OSSM system works, what to do, what not to do and a training awareness program. Provide details of an education program that includes responsibilities for the owners, staff and general public. A maintenance plan is needed that will include information on trouble shooting what to do if something goes wrong with the OSSM system, and emergency procedures and contacts etc
- Detail how often the OSSM system will need to be serviced, include a copy of the standard service report check list, state the qualifications of the service person and the time intervals to send service reports to BSC Development and Environmental Health Group. For Commercial scale systems quarterly sampling and reporting is required
- BSC will perform a monitoring and auditing role to ensure that the OSSM system continues to operate satisfactorily. The audit interval is to be determined based on a risk assessment process. All servicing reports are to be kept on-site and copies provided to BSC. Refer to BSC OSSM Factsheet 10 - Commercial OSSM Applications >10EP Guide for Consultants, which is accessible on BSC website.

#### **Commercial OSSM - Intermittent Decanting Extended Aeration (IDEA) Plant**





# OSSM EFFLUENT LAND APPLICATION AREA CALCULATIONS

It is important to select the appropriate method of applying the effluent to the land, based on the risk to downstream environment, climate data, wastewater volumes generated, soil classification and size of area required.

The effluent land application area is to be designed and configured to limit the risk of effluent overflow during high rainfall months and/or export of nutrients into the downstream environment. These risks are reduced by designing and sizing the effluent land application area based on the most limiting sized area calculated from the hydraulic load, water and nutrient balance.



When using the water balance method the maximum monthly cumulative stored effluent amount (within trench/bed) should not exceed 200mm

For sub-surface irrigation systems, it is recommended to have zero in-ground effluent storage throughout the year.

## Three Calculations Required

1. Hydraulic Load – based on wastewater volume and soil permeability;
2. Monthly Water Balance – based on wastewater volume, soil permeability and climate data;
3. Annual Nutrient Balance – based on soil properties, nitrogen and phosphorous loads per capita.

The effluent land application installation area (ie trenches and/or sub-surface irrigation pipework) is sized based on the largest calculated area from equations 1 and 2 and the total effluent land application area is sized based on the largest calculated area from equations 1, 2 and 3.

The total effluent land application area is determined by adding the effluent land application installation area including the spaces between trenches or sub-surface irrigation pipework and any additional buffer of land area required downstream of the installation area to achieve the total effluent land application area.

## Example:

Parameters - Alstonville mean rainfall data, Alstonville pan-evaporation data, soil assessment DLR 8mm/day, primary wastewater treatment, wastewater volume – 3 bedrooms –  $4.5EP \times 150 \text{ litres/EP} = 675 \text{ litres/day}$ .

Calculated Hydraulic Load - ETA bed area =  $84.4\text{m}^2$   
 Calculated Water Balance – ETA bed area =  $114\text{m}^2$   
 Calculated Nutrient Balance - ETA bed area =  $443\text{m}^2$

This means the effluent land application installation area would be sized on  $114\text{m}^2$  (water balance result) and the total effluent land application area would be sized on  $443\text{m}^2$  (nutrient balance result). An additional  $329\text{m}^2$  of land area ( $443\text{m}^2 - 114\text{m}^2 = 329\text{m}^2$ ) is to be provided to achieve the total effluent land application area. The additional land area is made up from the spaces between the ETA beds and land downstream of lowest trench/bed (see diagram overpage).

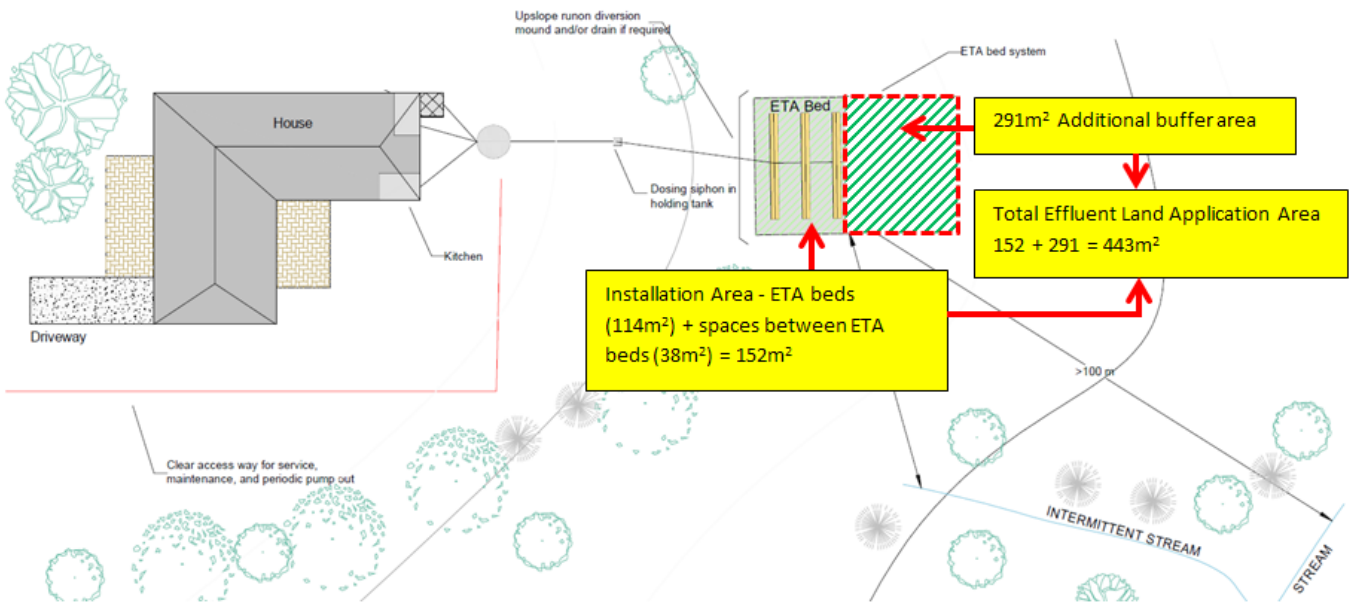

Acceptable Water and Nutrient Balance Calculation Methods

1. OSSM Design Model Program - ie Use Lismore City Council, or Byron Shire Council or other equivalent OSSM model programs that have the Lismore-Ballina soil landscapes incorporated into the program.
2. OSSM Designer's Calculations – ie spreadsheets.



Refer to Appendixes C and D for examples of Hydraulic Load, Water and Nutrient Balance equations.

## Wisconsin Sand Mound Systems

The Some guidance is provided by AS/NZS 1547: On-site domestic wastewater management – Appendix N - Land Application Methods - Mounds. More detailed guidance can be obtained from Wisconsin Mound Soil Absorption System; Siting, Design and Construction Manual (Converse and Tyler, 2000).

### Sand Mound Design Sizing & Installation Steps

- Determine the wastewater volume: hydraulic load (eg 3 bedrooms – 4.5 EP x 150 L/EP/Day = 675 Litres/day);
- Determine width of distribution bed: The general width of a sand mound distribution bed is between 1.2m–2.0m wide. If the soil profile (permeability) below the base of sand mound is restrictive (ie clay, rock) then the distribution bed configuration is narrow and long and conversely for very permeable soils (sand) below sand mound the distribution bed is wider and shorter in length;
- Determine the sand mound media loading rate (SLR) and size of distribution bed: (maximum loading rate 40 mm/day for primary treated effluent and 50mm/day for secondary treated effluent). **Example:**  
 Length of distribution bed =  $Q / (SLR \times \text{Width bed})$   
 Length of distribution bed =  $675 / (40 \text{ mm/day} \times 1.5\text{m})$   
 Length of distribution bed = 11.25m  
 Distribution bed size = 11.25m long x 1.5m wide

Or alternatively, use the coarse sizing method - length of distribution bed equates to 6–8 times the width of distribution bed, eg  $8 \times 1.5\text{m}$  (width) = 12m (length of bed);

- Determine basal loading rate and size of basal area: The sand mound basal area is determined by soil assessment, the recommended design loading rates in AS/NZS 1547 Table N1 and sizing method in Appendix N.

Sand Mound Sizing Example:

AS/NZS 1547 coarse sizing method for slopes < 3% is - Basal Area = Length x Width A + (2 x l)

A = width of distribution bed (eg 1.5m)

l = ground slope 1:3 (eg if height of sand mound is 1m then "l" = 3m)

Basal width =  $A + (2 \times l)$

Basal width =  $1.5 + (2 \times 3)$

Basal width = 7.5m

Basal Length =  $B + 2 \times K$

B = length of distribution bed (eg 11.25m) K = ground slope 1:3 (eg 3m)

Basal Length =  $11.25 + (2 \times 3)$

Basal Length = 17.25m

Basal Area = Length x Width A + (2 x l)

Basal Area =  $17.25 \times (1.5 + (2 \times 3))$

Basal Area = 17.25m x 7.5m



When the soil below the sand mound (basal area) is heavy clay then it is recommended to perform a cross check of the sand mound coarse sizing method using AS/NZS 1547 equation -  $L = Q / (DLR \times W)$  to determine basal area.

L = Length of bed (?)

Q = Daily wastewater volume generated (eg 675 litres)

DLR = Design Loading Rate (eg 5mm/day)

W = Width of bed (7.5m)

$L = Q / (DLR \times W)$

$L = 675 / (5 \times 7.5)$

$L = 675 / 37.5$

L = 18m

Basal Area = 18m x 7.5m (if the basal area needs to be increased then the distribution bed and 1:3 slope would need to be adjusted to suit the increase in basal area)



- e) Determine the linear loading rate: If the soil below the sand mound basal area is restrictive (clay, rock) and the movement of effluent is primarily horizontal then the linear (toe) loading rate shall not exceed 50L/m/day. Example, 675 (litres/day)/50 Litres = 13.5m (minimum length of sand mound linear toe). In the equation above the linear toe length is calculated as 17.25m or 18m, which is greater than 13.5m, so the linear loading rate is not exceeded and is OK;  
Conversely, if the soil below the sand mound basal area is un-restrictive (sand) and the movement of effluent is primarily vertical then the linear (toe) loading rate shall not exceed 125L/m/day. Example, 675 (litres/day)/125 Litres = 5.4m (therefore the minimum length of sand mound linear toe is to be 5.4m for an unrestrictive sand soil);
- f) To achieve the optimal performance of a sand mound it is recommended to provide small dosing volumes of effluent into the sand mound via closely spaced orifices into the distribution bed pipework (eg PVC manifold pipework). Consideration should be given to providing surge capacity (eg wastewater holding tank) and time dose the effluent pump volumes into the sand mound;
- g) The sand mound media is to be medium clean sand (ie washed sand) with a grain size of 0.25mm–1.0mm, uniformity coefficient less than 4, less than 3% fines passing a 200 sieve (0.074mm), less than 20% of grains greater than 2mm, free of clay, limestone and organic material in sand media. The installer is to obtain certification from sand supplier that the sand meets this criteria or alternatively have the sand media tested at a soil laboratory for compliance with criteria. The installer is to provide the council inspector a copy of the soil laboratory test results prior to installation. The distribution bed aggregate is to be river run aggregate (20– 60mm, non-crushed and rounded);
- h) Ensure that the sand mound surface area is covered directly after construction with appropriate grass/turf to complete the installation process and to prevent erosional disturbance occurring to the sand mound. The 1:3 slope on the sand mound is required to assist in preventing effluent toe leakage and to ensure safe maintenance of the sand mound.



Note: AS/NZS 1547 Appendix N and table N1 refers to primary treatment wastewater quality in regard to the sand mound effluent application rate and design loading rate used to size the basal area. If the quality of wastewater treatment is to be of a higher standard (ie secondary effluent quality standard) then it may be reasonable to increase the sand mound application and basal design loading rates. The OSSM designer would need to justify and support any increase in application and loading rates that differ from AS/NZS 1547 Appendix N and table N1.

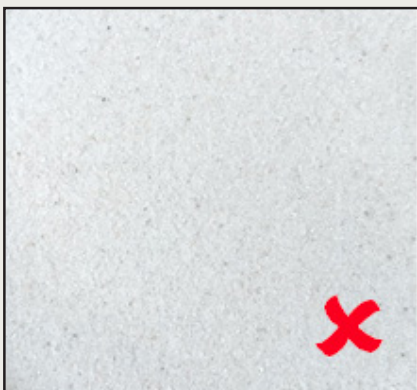

Figure 1: Fine Grain Sand

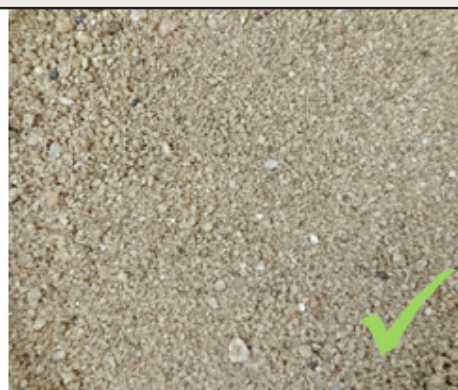

Figure 2: Medium Grain Sand

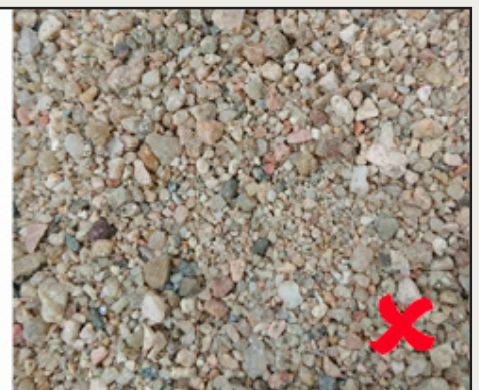
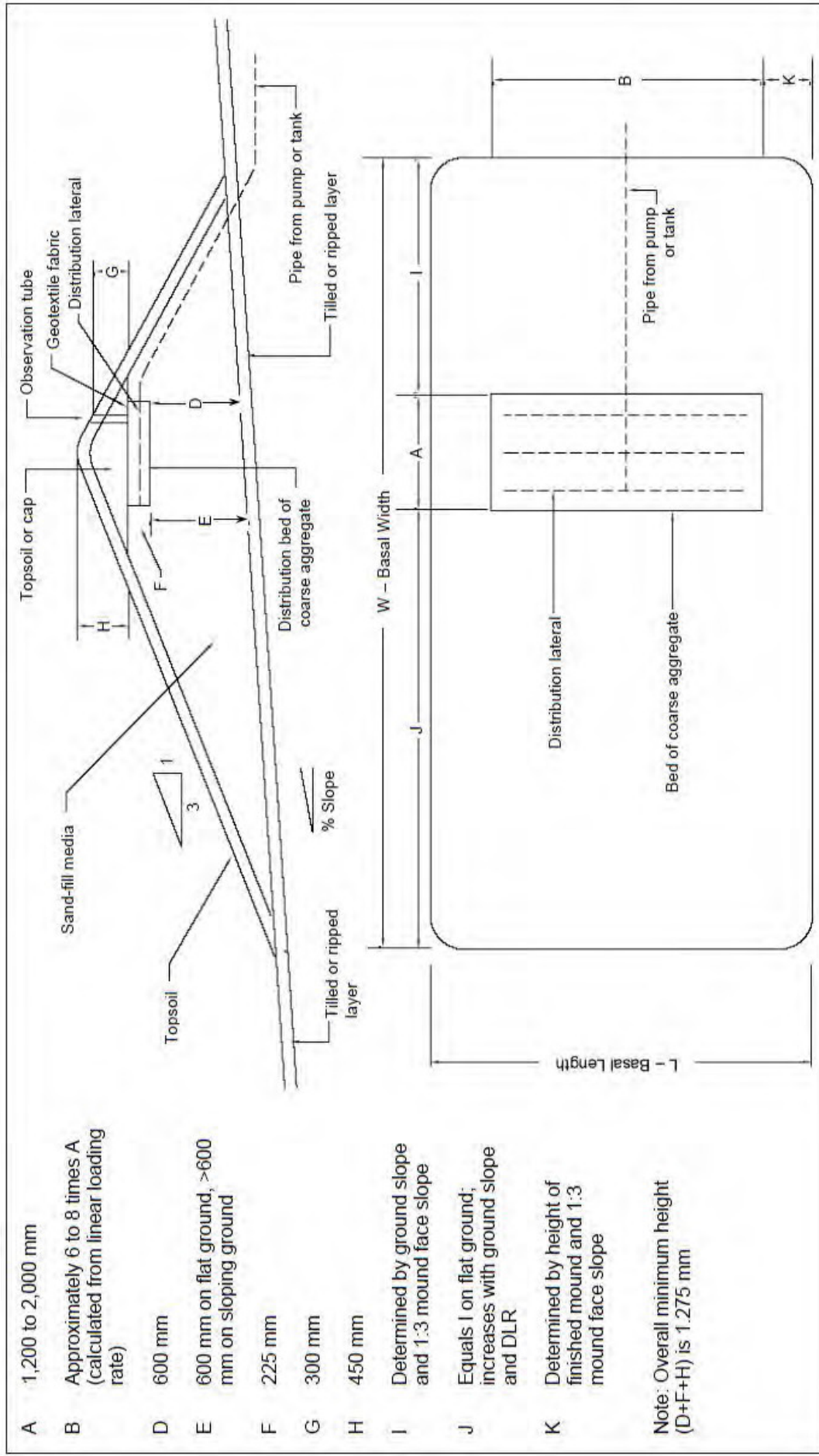

Figure 3: Coarse Grain Sand



Design and Installation of On-site Wastewater Systems



- A 1,200 to 2,000 mm
  - B Approximately 6 to 8 times A (calculated from linear loading rate)
  - D 600 mm
  - E 600 mm on flat ground, >600 mm on sloping ground
  - F 225 mm
  - G 300 mm
  - H 450 mm
  - I Determined by ground slope and 1:3 mound face slope
  - J Equals I on flat ground; increases with ground slope and DLR
  - K Determined by height of finished mound and 1:3 mound face slope
- Note: Overall minimum height (D+F+H) is 1,275 mm

**Standard Drawing 9B - Wisconsin Sand Mound**  
(not to scale)

# WICK TRENCHES

Wick Trenches are an emerging technology developed by Kerry Flanagan Wastewater that may offer an alternative solution when confronted with significant site constraints ie small sites and low soil permeability.

The Wick Trench is a modification on the traditional evapotranspiration absorption trench. The design increases the evapotranspiration area by increasing the width of evaporative surface and incorporating geotextile fabric in the installation to create a wick effect. By increasing the surface area of the trench (doubling the width) will allow more effluent to be drawn up through soil, grasses and for evapotranspiration to occur.

## Cross Section of Wick Trench

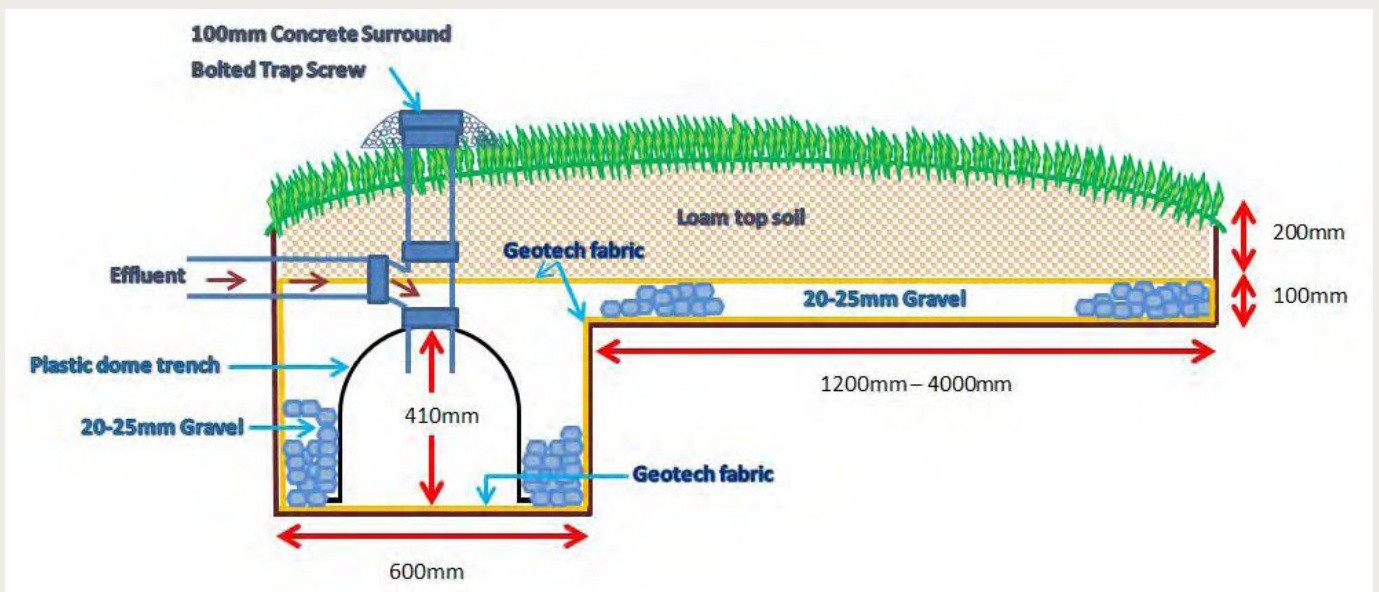

## Wick Trench Installation Photos





**Calculating the Size of Wick Trench - Comparison****Traditional Absorption Trench Sizing Example:**

AS/NZS 1547: Formula -  $L = Q / (DLR \times W)$

L = Length of trench (m)

Q = Wastewater volume (litres)

DLR = Design Loading Rate (mm/day) Parameters:

Three bedroom dwelling –  $3 \times 1.5EP = 4.5EP$

Wastewater volume -  $4.5EP \times 150 \text{ litres/day} = 675 \text{ litres}$

Category 4 – clay loam soil = 10 mm/day

Width of dome arch trench = 0.6m

$L = Q / (DLR \times W)$

$L = 675 / (10 \times 0.6)$

L = 112.5m

**Therefore 6 x 18.75m dome arch trenches are recommended**

**Wick Trench Sizing Example:**

$L = Q / (DLR \times (\text{Total width bed} / \text{Wick bed width}))$

Parameters:

Three bedroom dwelling –  $3 \times 1.5EP = 4.5EP$

Wastewater volume -  $4.5EP \times 150 \text{ litres/day} = 675 \text{ litres}$

Category 4 – clay loam soil = 10 mm/day

Width of dome arch trench = 0.6m

Wick bed width = 1.2m

Total bed width = 0.6m dome arch trench + 1.2m wick width = 1.8m

$L = Q / (DLR \times (\text{Total bed width} / \text{Wick bed width}))$

$L = 675 / (10 \times (1.8 / 1.2))$

$L = 675 / (10 \times 1.5)$

$L = 675 / 15$  L = 45m

**Therefore 3 x 15m dome arch trenches are recommended**

**Key Installation Notes:**

- Minimum 300mm soil depth is required for trenches and beds for non-disinfected effluent
- The trench and bed are to be installed on level ground surface, if the land is uneven or sloping then terracing of the ground may be required
- Avoid filling hollows across the contour as this may interfere with effluent distribution
- Lay geotextile fabric in a continuous length across the trench and pan ie down the outer side wall of the trench, across the base of the trench, up the inner side wall of the trench, across the base of the pan and up the outer side wall of the pan. This is the 'wick'

- Spread clean recycled 20 millimetre gravel across the pan and into the trench. Gravel should be as clean as possible. Some recycled gravel may not be washed (check with your supplier)
- Place another layer of geotextile fabric over the top of gravel layer to prevent the top soil washing into the gravel
- Select a good permeable soil for back filling. Never backfill with the clay soil from the lower soil horizons. Ensure uniform depth of soil across the finished surface of the installation to provide even performance along the trench
- Ensure that connection points can be inspected whether pumped or gravity fed. Use inspection openings at trench entry points and connection points to other trenches
- Install a mica-flap vent at ground level, at the end of the trench to allow air to flow through the trench, up the drain line into the tank, and continue up the drainage and expel through the roof vent. This will improve the environment in the system by increased aeration
- The effluent land application area (Wick Trench) ground surface level, is to be minimum 100-150mm below the invert of septic tank outlet pipe. If the septic tank outlet pipe invert is 400mm below the top of septic tank lid then the ground surface level where the "Wick Trench" is installed must be at least 550mm below the top of septic tank lid
- If it is not possible to achieve the 550mm height separation between top of septic tank lid and top of Wick Trench ground surface level then a pump and collection well system will be required (including non-return valve, high level alarm)
- The septic tank must be desludged at appropriate intervals to ensure that the sludge does not flow into the trench, reducing trench performance.

# SITE PLANS

A site plan is to be prepared and submitted with the OSSM Approval to Install Application (contained within the OSSM Design Report). The site plan is to indicate the location of site boundaries, existing and proposed buildings and associated development, site features (ie contours, soil landscape boundaries), OSSM system and effluent land application areas and include measurements on the plan confirming the distance to boundaries, stormwater drainage channels, creeks, rivers, dams, groundwater bores etc.

# PLUMBING AND DRAINAGE AND ASSOCIATED PIPEWORK

All plumbing and drainage works are to be performed by a NSW licenced plumber and drainer in accordance with the Plumbing Code of Australia. Plumbing and drainage works, in regard to OSSM, is defined as pipework upstream of the OSSM system inlet.

A Local Government Act Section 68 Application is to be lodged with BSC if you are proposing to carry out water, sewerage and stormwater works that is or will be connected into BSC infrastructure. If you carrying out plumbing and drainage works that will not be connected into BSC water, sewerage or stormwater infrastructure then a Local Government Act Section 68 Application is not required. However, all plumbing and drainage works must be inspected by BSC before being covered. The Department of Fair Trading Plumbing & Drainage Notice of Work form is to be lodged to BSC prior to works commencing and Certificate of Compliance provided after works are completed.

The water source within pressurised pipework must be identified by installing underground marking tape to AS/NZS 2648.1 over the buried pipework (ie sub-surface irrigation, low pressure effluent distribution system or pumped effluent pressure pipe), alternatively the pressurised pipe must be colour coded and stamped at the required spacing (eg 1m intervals stamped on pipe) indicating its water source.



BSC charges fees to inspect plumbing and drainage works and the fees must be paid before inspections are undertaken. Contact BSC to confirm inspection fee charges.

## RECLAIMED RECYCLED WATERLINE BURIED BELOW DO NOT DRINK

Colour Identification	Application
 Black	Non Potable Water
 Blue Stripe	Potable Water
 Blue	Water (New Zealand)
 Purple Stripe	Recycled Water
 Cream Stripe	Pressure Sewer

# BACKFLOW PREVENTION IN NON-SEWERED AREAS

All non-sewered properties within the BSC LGA that have a Greywater Treatment System installed (disinfected recycled water supplied to specific plumbing fixtures and outdoor taps) and which are also connected to the Council's reticulated water supply shall have a medium testable backflow prevention device installed at the boundary on the property owner's side of the water meter at the owners' cost.

The property owner will need to lodge to Council a Local Government Act Section 68 Application to carry

out water supply work for the installation of a backflow prevention device and pay the required fees.

Where a Greywater Diversion Device (GDD) is installed, within a BSC reticulated water supply area, the NSW licenced Plumber and Drainer or property owner shall notify Council to ensure that a water meter with an integral dual check valve is installed on the water service for the property. GDD can only be installed for single residential properties.

# OSSM AND MOBILE VENDING (FOOD) REQUIREMENTS

If intending to operate a mobile vending business on public land, then refer to BSC's "Mobile Vending on Public Land" policy for permit approval and operation requirements.

The following is required if you are intending to operate a mobile vending (food) business on private property within the BSC LGA non-sewered area:

- a) Depending on the situation you may need to lodge a Development Application to operate a mobile vending (food) business and/or obtain approval to locate the business on a particular section of land on the property;
- b) Lodge a Local Government Act Section 68 Application to Install an OSSM system (if unable to connect to Council's sewerage reticulated system);
- c) Submit with the application an OSSM Design Report prepared by a suitably qualified person detailing how you will manage the wastewater generated from the mobile vending (food) business ie will a portable wastewater holding tank be provided on-site, which will be regularly pumped out by an authorised wastewater pumpout contractor, or alternatively will the mobile vending (food) plumbing and drainage be connected into an existing OSSM system;

- d) Confirm the quantity and quality of wastewater generated from the mobile vending (food) operations, where is the wastewater draining into, is the OSSM system suitably sized and appropriate for intended purposes and located in a suitable position on-site to allow access for pumpout;
- e) The OSSM system location is not to cause any amenity issue to property occupants and/or neighbours ie noise and odour issues as a result from the pumpout operation;
- f) All plumbing fixtures inside the mobile vending (food) ie kitchen and basin sinks, are to be connected into the OSSM system via sanitary plumbing and drainage pipework;
- g) All plumbing and drainage work is to be in accordance with the Plumbing Code of Australia and installed by a NSW licenced plumber and drainer;

- h) Council is to issue the OSSM approval to operate certificate prior to commencement of the mobile vending (food) operation;
- i) NSW licenced Plumber is to install vacuum breaker devices on all hose taps, adjacent to the mobile vending (food) location, that could potentially supply drinking water to the mobile food van. If you are not using BSC's reticulated drinking water supply (for food preparation, cooking, drinking purposes), the alternative private water supply must meet drinking water standards and have a Quality Assurance Program in operation. The Quality Assurance Program must be submitted to NSW Ministry of Health prior to business operation;
- j) All water sources and water storage containers for food van operations are to be identified with signage indicating their source and/or contents ie drinking water, wastewater;
- k) Department of Fair Trading plumbing and drainage forms are to be lodged to BSC and any inspection fees paid;
- l) Hand wash basin hot water is not to exceed 50°C;
- m) The mobile vending (food) is to be approved and inspected by BSC OSSM Officer and Environmental Health Officer prior to commencement of business.



All home based businesses in non-sewered areas that use water, generate wastewater and/or prepare food may need to obtain approval from BSC to operate the business and/or for certain aspects of the operation, which will be similar to the Mobile Vending (food) requirements above. Contact BSC to confirm inspection fee charges.

## Ecologically Sustainable Development

All new or alterations to existing buildings connected to OSSM systems are to install water and energy efficient plumbing products (where applicable) to conserve the water and energy supply, minimise wastewater generation, assist in the satisfactory operation of the OSSM system and reduce the risk of the system failing.

The details of the water and energy efficient products are to be included within the OSSM Design Report. All plumbing fixtures and products must have the required WaterMark certification licence and not exceed the maximum water flow rate limits set within the Australian Standard AS/NZS 3500.1 Water Services.

The OSSM designer will need to confirm, for existing buildings, the current and new water efficiency products to be installed and justify the daily wastewater volumes generated. If it is not possible to replace the existing washing machine and/or dishwashing machine at this time to current new water efficiency standard products then the OSSM system upgrade works must reflect and be sized on the actual wastewater volumes generated.

There are many water and energy efficient plumbing fixtures and products on the market that significantly reduce water and energy consumption below the maximum limits. The less water consumption means less wastewater generation and less potential impacts on your OSSM treatment system and reduction in size of the effluent land application area. Consult with a NSW Licenced Plumber and Drainer or Hydraulic Consultant in regard to balancing the water supply system.

Refer to the Australian Government Water Efficiency Labelling Standards (WELS) scheme and Energy Rating websites to compare the water and energy efficiency of different products.





In addition to water and energy efficiency plumbing products the following elements need to be considered by the property owner and OSSM designer when installing a new or altering an existing OSSM system.

- can a passive OSSM system be installed (limit electrical power supply consumption, alternative power sources)
- reduce the OSSM ongoing financial costs eg consider the type of OSSM system to be installed ie daily electrical power usage requirements, are chemical additives needed (eg chlorine disinfection), maintenance servicing frequency and costs, etc
- options of incorporating recycled water initiatives, cost benefit analysis for large wastewater volume generators and developments
- management of waste ie reduce organic matter discharging into OSSM system, strainer in kitchen sink, food scraps composted, wipe grease and oil off plates/pans and not washed down sink
- homeowner and occupier encouraged to take responsibility for satisfactory operation of OSSM system ie selection of washing and cleaning products with no bleach, reduced phosphorous and sodium additives, monitor the performance of the OSSM system and ensure maintenance works are undertaken.

## OSSM OPERATION AND MAINTENANCE PLANS

The OSSM Approval to Install Application must be accompanied by details of:

- a) The operation and maintenance requirements for the proposed sewage management facility including the effluent land application area;
- b) The proposed operation, maintenance and servicing arrangements intended to meet those requirements;
- c) The action to be taken in the event of a breakdown in, or other interference with, its operation.

## OSSM CERTIFICATION

All stages of the design, installation and commissioning of an OSSM system are to be certified by suitably qualified people.

**Table 5: OSSM Certification Requirements**

CERTIFICATION TYPE	CERTIFICATION PERSON	CERTIFICATION DOCUMENT
OSSM Design Certification	Suitably Qualified Person – ie Designer - Wastewater Consultant or NSW Licenced Plumber and Drainer	BSC – Design Producer Statement
OSSM Installation and Commissioning Certification - new and upgraded On-Site Sewage Management Systems	NSW Licenced Plumber and Drainer	BSC – Compliance and Commissioning Certification Form
OSSM Installation and Minor Alterations Certification	Suitably Qualified Person – ie Designer - Wastewater Consultant or NSW Licenced Plumber and Drainer	BSC - Installation and Minor Alterations Certification Form

## Guide for Swimming Pool and Spa Bath Backwash and Overflow Discharges – For Non-Sewered Areas

A swimming pool recirculation system pumps pool water through either a cartridge filter or sandfilter where the suspended particles are trapped and the clean water is returned to the pool. As the build-up of dirt in a sandfilter increases, so the water pressure rises and the flow decreases. When the pressure reaches an unacceptable level, the flow must be reversed to clean the sandfilter media via a process called “backwashing” which discharges the dirty water to waste.

The swimming pool backwash discharge for sand filter systems and pool overflow pipe (if applicable), must not discharge into an OSSM system or terminate in a location that will impact on the effluent land application area.

The backwash discharge pipe and/or pool overflow pipe is to drain into a separate stormwater dispersion pit or trench that is located downstream of the effluent land application area or in a position where it will not flow into the effluent land application area. The overflow from the dispersion pit or trench must not cause soil erosion, or be directed into neighbouring properties or result in water pollution (ie discharge into waterway).

### Guidelines for pool backwash dispersion pit:

- minimum dimensions of dispersion pit 1m<sup>3</sup>, filled with 20-40mm crushed rock
- the dispersion pit must be positioned minimum of 6m (setback) from downstream boundary
- the swimming pool backwash and/or overflow pipe must not discharge onto the ground surface or into neighbouring properties or into waterway
- swimming pool sandfilter backwash PVC pressure discharge pipe is to connect into the dispersion pit via 100mm DWV junction with 100mm DWV slotted vertical dropper, the upper pipe from junction is to be fitted with 100mm DWV prefabricated concrete surround grated gully top. The gully top is to terminate 75mm above ground surface level. The grated gully top must not be a loose grate it is to be a pop top type (see below) so that the gully grate is permanently connected to the fitting and will not be washed away
- this dispersion pit guide is based on typical domestic swimming pool capacities and sandfilter sizes. There are many variables to consider in the dispersion pit design ie sandfilter backwash and rinse time cycles (eg 2min backwash and 1min rinse), maximum sandfilter flowrates, pump duty, soil permeability and if the soil is saturated due to wet weather. If the pool size is non-domestic and large volumes of waste are being generated during the backwash cycle then specialist advice and design would be required for the dispersion pit.



100 DWV gully with pop top

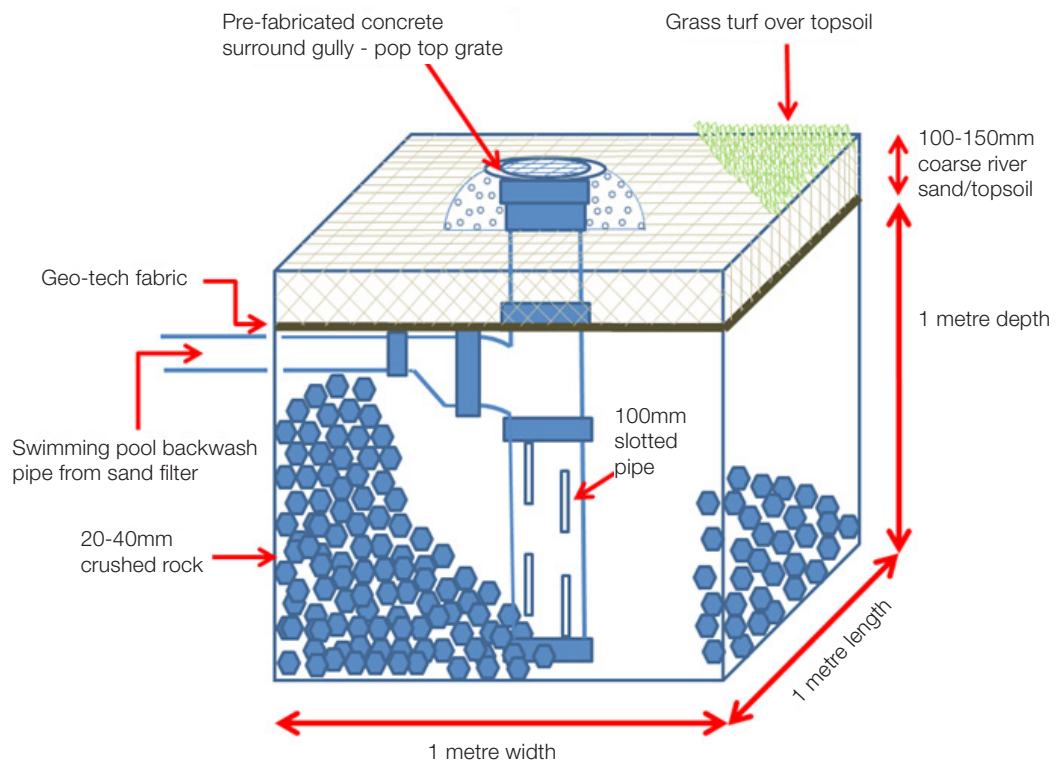

Cross-section of typical 1m<sup>3</sup> dispersion pit for swimming pool backwash discharge from sand filter

## Existing Properties in Non-Sewered Area - Proposal to Connect into Council's Sewerage System

For non-sewered areas within the BSC LGA that are not part of the "Backlog Sewer Program", which means this area is not identified by Council as an area to be connected into the BSC reticulated sewerage system in the foreseeable future, it may be feasible for the homeowners to apply to BSC to be connected into the BSC sewerage system under certain conditions.

Conditions and brief overview of process:

- there must be a need for the non-sewered properties/owners to apply to BSC to be connected into the reticulated sewerage system, eg unsatisfactory performance of existing OSSM systems, failing systems and substantiation that there is a public and environmental health risk
- BSC sewerage infrastructure must be in close proximity to subject location and there must be sufficient capacity within the infrastructure to receive the additional wastewater
- to determine feasibility BSC would obtain quotes for the proposed installation works and confirm headworks charges (sewerage treatment and infrastructure maintenance charges)
- subject property owners must agree that they will connect into the sewerage system and pay 100% of installation costs, headworks charges, application and inspection fees
- Local Government Act Section 68 Application and Part V Development Application (Internal Council application) would need to be lodged and approved by BSC for the proposed connection into the BSC sewerage system. (application to include engineering drawings, specifications etc)
- a contractor is awarded the contract to install the BSC sewerage infrastructure and provide a connection point for each property owner. The property owner has the additional responsibility and costs of connecting their sanitary drainage pipework into the BSC sewerage connection point (including decommissioning of the existing OSSM system)
- homeowner to make repayments to BSC for the installation and headworks charges as detailed in a signed agreement between both parties. Sewerage rate charges will commence once the sewerage infrastructure has been commissioned and the connection point has been provided.

## APPROVAL TO OPERATE APPLICATION - REQUIREMENTS

Under Section 68 of the Local Government Act 1993, Council approval is required for the ongoing operation of an On-Site Sewage Management System.

The Approval to Operate an On-Site Sewage Management System (other than renewal) will only be issued to the owner of a property where:

1. For a new OSSM system; a final inspection has been undertaken and when all certification documentation has been received by Council; or
2. For an upgrade of an existing OSSM system resulting in a change to the type of system installed eg a new wastewater treatment system and/or installation of a new effluent land application area (trenching); a final inspection has been undertaken and when all certification documentation has been received by Council. The new certificate will reflect the modified system; or
3. For a property that is serviced by an OSSM system and is sold, the new property owner may continue to operate the existing system of sewage management for a period of up to three months after completion of the sale, but an application to Council must be lodged within two months of completion of the sale for the OSSM Approval to Operate certificate to be issued in the new owner's name.



Note: BSC is proposing to introduce the compulsory re-inspection of existing OSSM systems by suitably qualified people (commencing 2020) when the OSSM Approval to Operate certificate is due to be renewed and prior to the property being sold. Refer to BSC OSSM Strategy sections 3, 4 and Table 1 for details.

# DEVELOPMENT APPLICATION REQUIREMENTS

For development applications in non-sewered areas the following is required:

## **Subdivision/Boundary Adjustment/Rezoning Applications**

- a) The development application is to include an OSSM Report prepared by a suitably qualified person, who has conducted an OSSM desktop study of the property, a site inspection and who has assessed any existing OSSM system/s. The OSSM Report must include details of the location of all existing OSSM systems on the property (including effluent land application areas), confirm; whether the existing systems are performing satisfactorily or unsatisfactorily; their location; their condition; and if they will affect the proposed development application;
- b) For development applications involving the subdivision of land into multiple parcels, the OSSM design report will need to include a desktop study, site and soil assessment details and justify that an OSSM system can be installed on the new parcel/s of land in accordance with BSC's OSSM Strategy and Rous Water On-Site Wastewater Management Guidelines if applicable.

The size and location of the subdivision will also determine the extent of content to be included in the OSSM Design Report. For large subdivisions (ie subdividing into greater than five parcels of land) and where the soil assessment characteristics are confirmed the OSSM designer may only need to justify that an OSSM system can be installed on the most limiting parcels within the subdivision.

This would mean a site and soil assessment and effluent land application area calculation, based on a standard four bedroom dwelling, is only carried out on the most limiting parcel/s, and not on every parcel of land. The most limiting size of effluent land application area would be indicatively placed onto a site plan for all parcels of land within the subdivision justifying that an OSSM system can be installed in accordance with BSC's OSSM Strategy and Rous Water On-Site Wastewater Management Guidelines if applicable;



The OSSM Designer is to consider and reference any applicable building envelop and environmental zones, within the OSSM Report and on the site plan, when determining the location of OSSM systems and effluent land application areas.

- c) If the OSSM Report finds that any existing OSSM system is unsatisfactory, the Report must set out in detail why this should not affect any consent given for the proposed development.

### **Example:**

- Confirm that a Local Government Act Section 68 application to alter/install an OSSM system has been lodged with Council to rectify the unsatisfactory performance of the system, or
- Advise it is the intention of the owner to lodge a Local Government Act Section 68 application to alter/install an OSSM system at a later date, justify the delay in rectifying the OSSM system and certify it will not cause an environmental or health risk in the meantime.

BSC will consider this information and may issue the development consent with appropriate conditions to ensure that any OSSM system upgrade works are completed (eg prior to issue of an occupation or subdivision certificate) and/or issue an "Order" to the property owner to rectify the OSSM system within a set timeframe;

- d) If the OSSM Report finds that the existing OSSM system is satisfactory, it must also confirm that if the system does require any future upgrades, and it will not affect any consent given for the proposed development;
- e) If an applicant is unsure of BSC requirements when lodging a development application, a request should be made for a pre-lodgement meeting with Council.



**New Dwellings**

For proposed new dwellings in non-sewered areas, on parcels of land 2000m<sup>2</sup> or less, and/or within a drinking water catchment area and/or within a POAA the following is required:

- a) The development application is to include an OSSM Report prepared by a suitably qualified person. The OSSM Design Report will need to include a desktop study, site and soil assessment details and justify that an OSSM system can be installed on the land in accordance with BSC's OSSM Strategy and Rous Water On-Site Wastewater Management Guidelines if applicable;
- b) Any approval will be conditioned to lodge a Local Government Act OSSM Section 68 Application (including payment of the application fee) prior to issue of Construction Certificate;
- c) An OSSM Approval to Operate certificate must be issued by BSC prior to the issuing of an interim or final occupational certificate;

For proposed new dwellings in non-sewered areas, on parcels of land greater than 2000m<sup>2</sup>, and not within a drinking water catchment area and not within a POAA the following is required:

- d) Any approval will be conditioned to lodge a Local Government Act OSSM Section 68 Application (including payment of the application fee) prior to issue of a Construction Certificate;
- e) An OSSM Approval to Operate certificate must be issued by BSC prior to the issuing of an interim or final occupational certificate.

**Alterations and Additions to Existing Dwellings**

For alterations and additions to existing dwellings in non-sewered areas where there is a proposal to increase the wastewater load (eg additional bedrooms) or an intention to carry out plumbing and drainage works (eg ensuite) the following is required:

**Prior to Issue of a Construction Certificate**

- a) A suitably qualified person is provide a report to BSC justifying that the existing OSSM system is operating satisfactorily, can treat the additional wastewater load and apply the effluent to the land, or confirm that the existing OSSM system will need to be upgraded, or that a new OSSM system will need to be installed;
- b) If the OSSM system needs to be upgraded or a new system installed then a Local Government Act OSSM Section 68 Application is to be lodged with BSC prior to issue of the Construction Certificate, including an OSSM Report prepared by a suitably

qualified person in accordance with BSC's OSSM Strategy and Rous Water On-Site Wastewater Management Guidelines if applicable. An OSSM Approval to Operate certificate must be issued by BSC prior to the issuing of an interim or final occupational certificate.

For alterations and additions to existing dwellings in non-sewered areas where there is no proposal to increase the wastewater load (eg no additional bedrooms) or no intention to carry out plumbing and drainage works the following is required:

- c) It is the homeowner and designer's responsibility to verify that the proposed development works (eg decking, building extension, swimming pool) will not be built over or impact on any existing OSSM system or effluent land application area. There is no requirement to submit an OSSM Report or lodge a Local Government Act OSSM Section 68 Application to BSC for these types of alterations and additions.

**Change of Building Use**

For change of building use development applications in non-sewered areas the following is required:

**Development Application Stage**

- a) A suitably qualified person is provide a OSSM Report to BSC justifying that the existing OSSM system is operating satisfactorily, can treat any additional wastewater load and apply the effluent to the land, or confirm that the existing OSSM system will need to be upgraded, or that a new OSSM system will need to be installed;
- b) If the OSSM system needs to be upgraded or a new system installed then a Local Government Act OSSM Section 68 Application is to be lodged to BSC including an OSSM Report prepared by a suitably qualified person in accordance with BSC's OSSM Strategy and Rous Water On-Site Wastewater Management Guidelines if applicable. An OSSM Approval to Operate certificate must be issued by BSC prior to the issuing of an interim or final occupational certificate.



If the Change of Building Use development application involves building works then the OSSM Report and Local Government Act OSSM Section 68 Application (if applicable) is to be lodged to BSC prior to issue of the Construction Certificate.

# EXISTING OSSM INSPECTION PROCESS

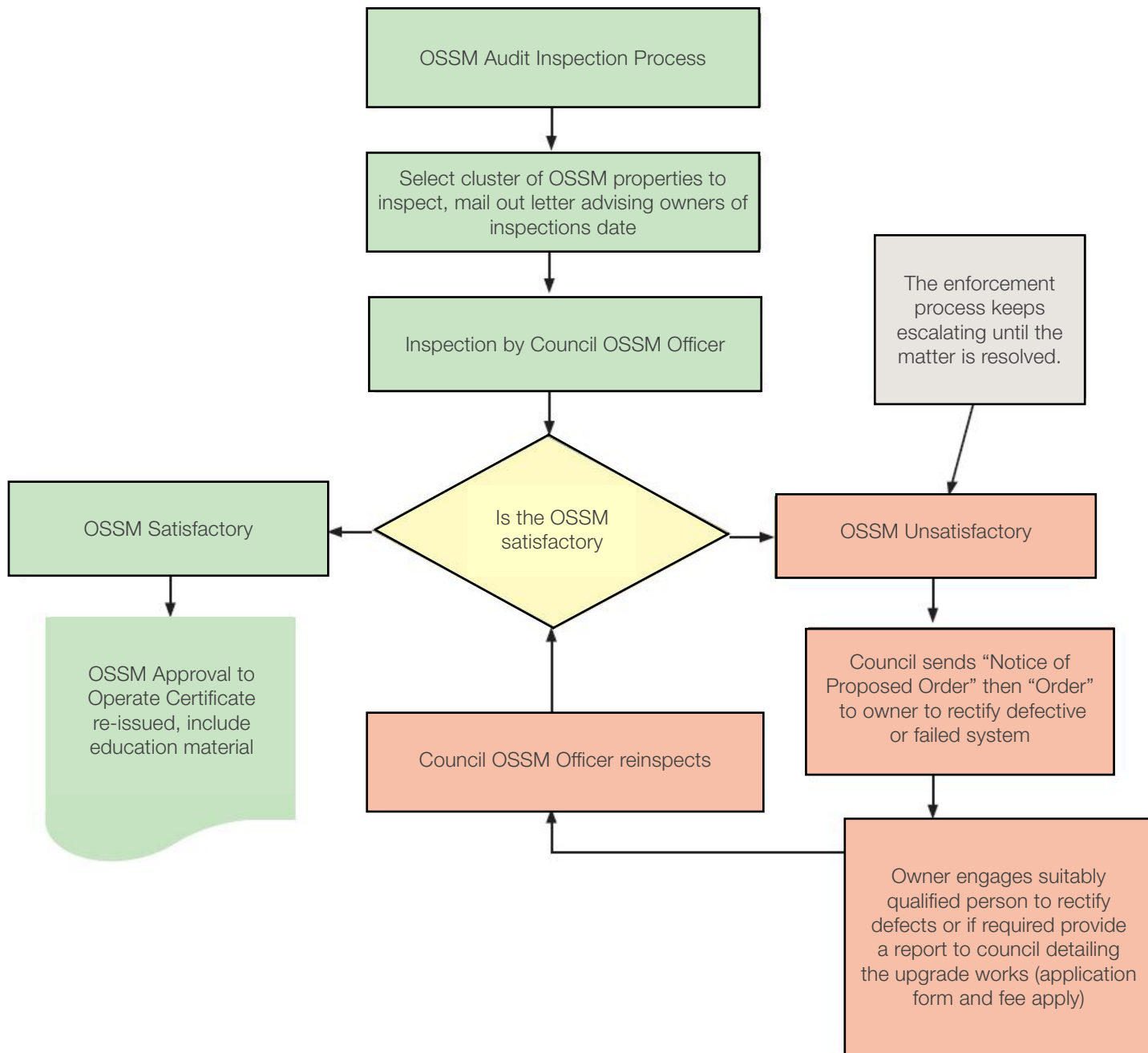

# OSSM TECHNICAL DRAWING - DEMAND DOSE PUMP WELL

(SOURCED FROM SYDNEY CATCHMENT AUTHORITY)



Design and Installation of On-site Wastewater Systems

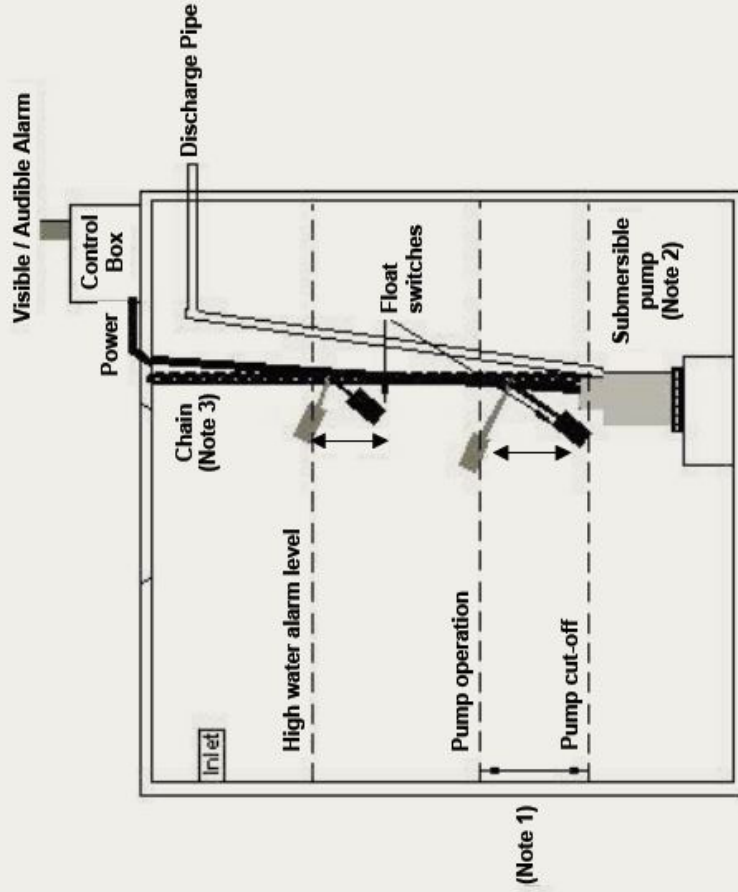

### Notes

- 1 The depth of effluent pumped within each cycle of the float switch (ie the depth between pump Cut-off and Operation) is calculated by:  

$$\text{depth of pumped effluent (m)} \times \text{basal tank area (m}^2\text{)} \times 1,000$$

$$= \text{discharge volume (litres per pump cycle)}$$

This volume must match the hydraulic capabilities of the receiving component based on flow rate and total dynamic head.
- 2 Submersible pump used as an example only. The pump will need to be selected based on the specific task. It may be a centrifugal pump or vortex pump depending on the type of effluent being pumped and the hydraulic characteristics of the system. It may sit on top of the tank and draw effluent from the tank.
- 3 Submersible pumps must not be removed from a tank by their power cord. Heavier pumps may require the installation of a solid steel bar configuration according to manufacturer's specifications.
- 4 Cumulative storage must be assessed carefully to ensure that the pump well is large enough to buffer peak loads without the level exceeding that at which the high level alarm is triggered. The pump well should be sized to ensure that the volume of storage in the pump well reaches the low-level cut-off depth at least once every week.

**Standard Drawing 12B - Demand Dose Pump well**

(not to scale)

# DOSING SIPHON & FLOUT

(SOURCED FROM SYDNEY CATCHMENT AUTHORITY)

Two emerging technologies that help with dose loading are described – the dosing siphon and the “Flout™”. Dose loading greatly improves performance compared with passively gravity feeding land application areas. This technology can provide a pressurised dose of effluent similar to what a pump would provide, without needing an electricity supply. This passive technology is well suited to sites where there is interrupted or no mains power supply, removing the need to replace pumps and provide electricity. Continual gravity loading of effluent management areas cannot be controlled; however dose loading using siphons (not for irrigation systems) or flouts can help ensure an effluent management area is used appropriately and not hydraulically over- or under-loaded.

## Dosing siphon

Dosing siphons are used extensively in the USA and are becoming more readily available from on-site wastewater system suppliers in Australia. They change low or variable flows into regular doses and suit pressurising laterals and land application areas. They have no moving parts and need no electricity. They are generally only recommended for use with sand filters (Figure 14.3) or absorption trenches/ beds or evapotranspiration absorption beds.

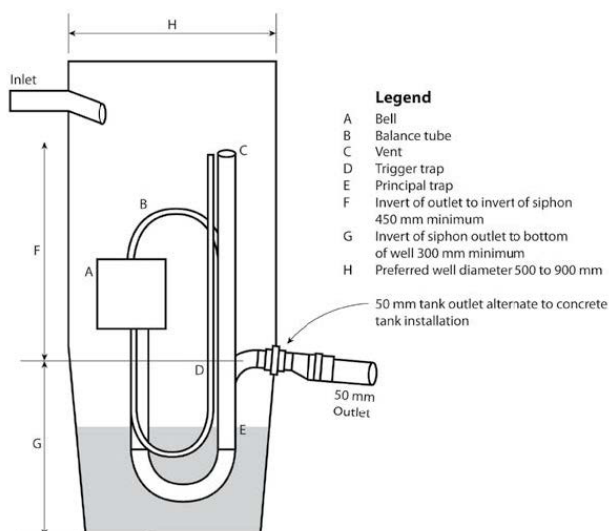

dosing chamber to the point where the dosing siphon is triggered. The volume of dose is determined by the diameter of the dosing chamber. After the dose is dispensed, the siphon breaks and the flow ceases. The siphon reliably resets and is automatically triggered again when the effluent level in the dosing chamber returns to the trigger level. Siphons are a low cost alternative to pumps and suit sites with no power or where power availability is limited. A fall of about 1.5 metres from the dosing chamber to the land application area is needed for the siphon to operate properly.

## Flout – floating outlet

The Flout® or Floating Outlet™ is a trademarked proprietary product made by Rissy Plastics. It is a simple dosing distribution device that can be used to dose load a land application area from a dosing well. As effluent from the septic tank fills the dosing chamber, the Flout™ is empty, buoyant, and floats on the surface. High quality, flexible connectors allow the Flout® to rise. When the effluent reaches the maximum level in the chamber, it spills into the opening in the top of the Flout®. This causes the Flout® to sink. The effluent now discharges through the pipe exiting the dosing chamber and doses the land application area. The chamber continues to empty down to the top of the Flout®. Then the Flout® empties and resumes floating to repeat another cycle. The Flout® can be used to dose load trenches and beds or effluent irrigation areas in some cases where there are differences in elevation between the treatment system and the disposal area.

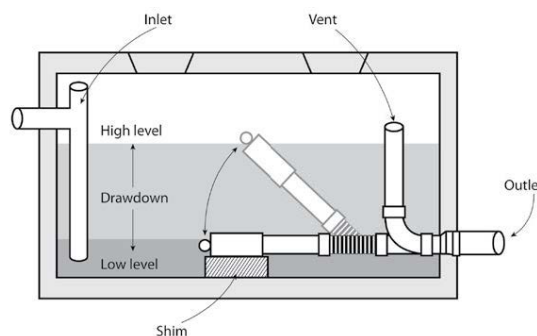



# TYPICAL ETA BED INSTALLATION

ETA Trench (Two distribution pipes) - SECTION VIEW

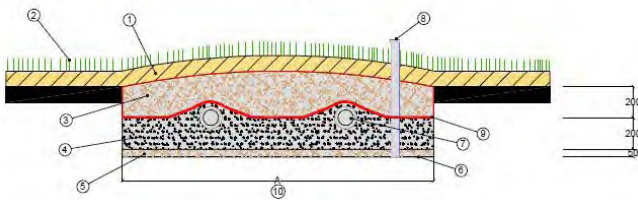

ETA Trench (Central distribution pipe) - SECTION VIEW

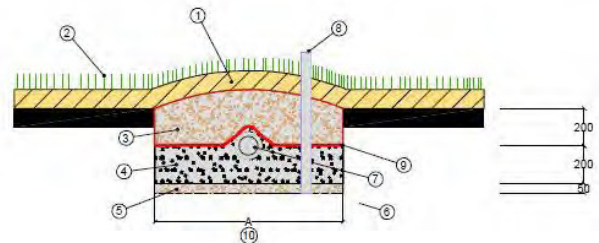

ETA BED - PLAN VIEW (not to scale)

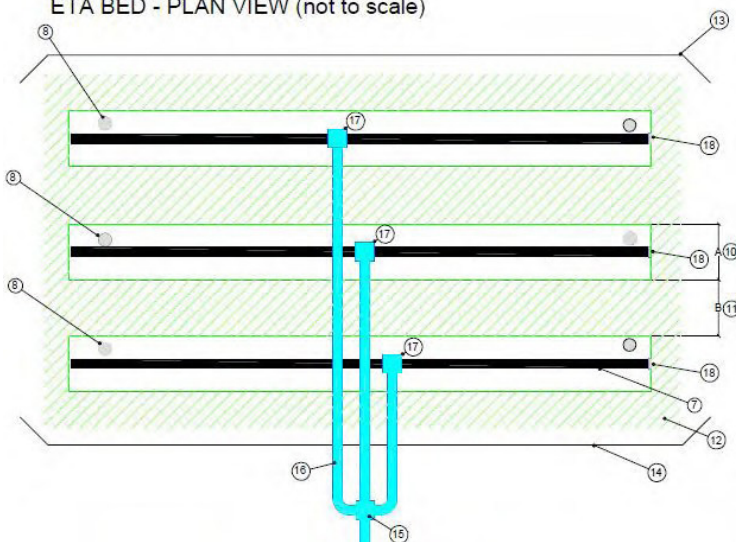

Component 7. 100 mm PVC pre-slotted pipe oriented and levelled to ensure even distribution of effluent

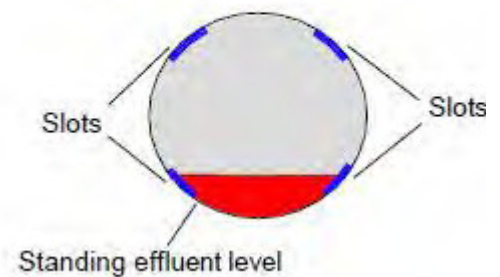

## ETA Beds - Minimum Components and Design Requirements

1. 100 mm of topsoil or backfilled local soils, mounded to reduce surface water infiltration.
2. Grass or other suitable cover (refer Council guidelines).
3. 100-200 mm of coarse packed sand.
4. 100-200 mm thick layer of 10-20 mm aggregate.
5. 50 mm thick sand cushion. Interface by raking existing soils prior to placing sand.
6. Flat base ETA bed to ensure equal distribution of effluent.
7. 100 mm pre-slotted sewer-grade PVC pipe. Additional distribution pipes are recommended with each metre in width, e.g. 2 m wide trenches require 2 pipes for even effluent distribution.
8. Inspection port to be placed on downhill side of each trench. Typically a 50 mm PVC piezometer.
9. Geotextile filter cloth.
10. ETA trench width – A (width ranges from 1000 – 4000 mm).
11. Spacing between ETA trenches - B. Spacing between trenches should be at least 1000 mm.
12. Trench dispersal area (m<sup>2</sup>). If greater than 1 m between trenches, calculate dispersal area as trench.
13. Downslope surface runoff collection drain. May be required if close to sensitive feature downstream.
14. Upslope run-on diversion and/or drain, required on all sloped sites.
15. Manifold distribution box, to be built from moulded PVC or pre-cast concrete, housed within 600mm x 600 mm stormwater pit with solid lid. Distribution box must be placed and levelled on 1000mm x 1000mm pre-cast slab or bedded in concrete.
16. Feeder pipe, typically 100 mm PVC pipe. Effluent should be intermittently dosed.
17. Splitter box, to be built from moulded PVC or pre-cast concrete. Box must be levelled.
18. End caps.

## APPENDIX A - AN IMPROVED VIRAL DIE-OFF METHOD FOR ESTIMATING SETBACK DISTANCES (W C CROMER, E A GARDNER AND P D BEAVERS) - EXAMPLE

### Viral Die-Off Method - Key Points & Parameters:

- Viruses are smaller and more resistant to natural die-off than bacteria, so if viral numbers (in effluent/soil) are acceptably low, then it is considered that bacterial numbers are also low
- For primary treated effluent it is recommended to use a viral reduction of 7, greywater a value of 5 and for secondary treated effluent a value of 3
- The order of magnitude values for wastewater treatment are:  
 Primary treatment - septic      7 order of magnitude 0.0000001  
 Greywater                              5 order of magnitude 0.00001  
 Secondary treatment              3 order of magnitude 0.001
- Be cautious when experiencing very low permeability soils because the low permeability input sometimes produces very small setback distances
- For “effective porosity” of the soil, it is recommended to use a number between 20% (0.2) and 35% (0.35)
- Groundwater temperature is the temperature of the wastewater in the soil. It varies seasonally, so reasonable inputs would be within the range of the minimum to maximum mean monthly air temperatures (Ballina mean monthly air temperatures, min 8.6°C max 19.9°C - Bureau of Meteorology). The setback distance decreases as temperature increases, so choosing a range of setbacks for the lowest temperature would be a conservative approach. For Ballina LGA it is recommended to use 14°C for wastewater temperature.

### The viral die-off method has two main steps:

**A.** Determine how much time is needed for viruses in effluent to naturally die off to acceptably low levels. To estimate this “Approx. viral die-off period”, the effluent quality and temperature of wastewater in the soil is to be nominated (refer Figure 2 and Equation 1), and

**B.** Determine how far the effluent has seeped laterally downgradient or cross gradient in that time period. To estimate this “Wastewater travel distance in die-off period”, we need to know the slope of the site, soil permeability and soil porosity (refer to Equation 2).

**Figure 2: Relationship between groundwater temperature and viral die-off time for various order-of-magnitude reductions in viral numbers**

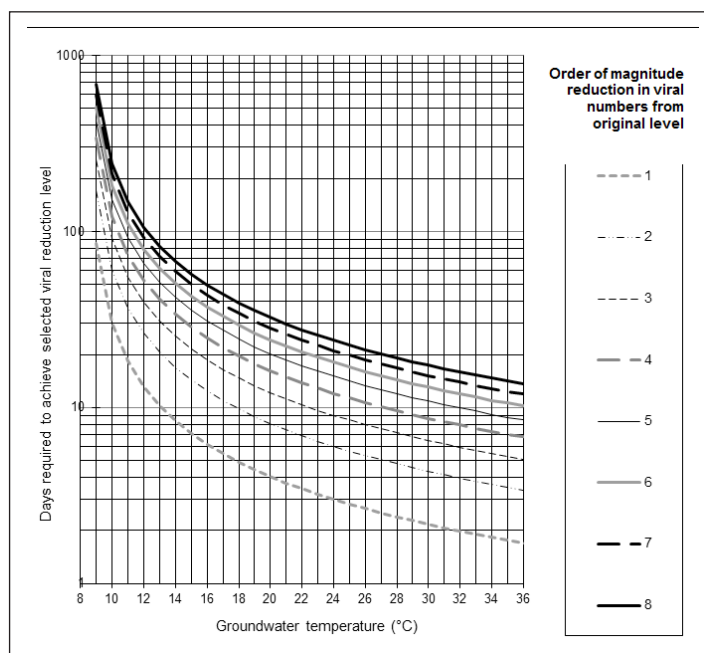

**Step A - Equation 1: Determine days required for viral reduction**

Example: Temperature 14°C and order of magnitude reduction value of 3 = 0.001 for secondary treatment.

Formula:  $M_t / M_o = e^{-kt}$

$M_t / M_o$  = is the dimensionless ratio between the viral concentration in the groundwater at any time  $t$  ( $M_t$ ) and the viral concentration in the wastewater at the time of its application to the subsurface ( $M_o$ )

$t$  = is the travel time (days) of the viruses in the groundwater

$k$  = is the first order rate coefficient for the die-off rate of the organism and is the temperature-dependent variable (°C). Viruses do not replicate outside host organisms.

Part 1 of Equation 1 - need to find value for (k) - (T = temperature 14°C)

$k = (T - 8.5) / 20$

$k = (14 - 8.5) / 20$

**k = 0.275**

Part 2 of Equation 1 - need to find travel time (t) - (Ln is natural logarithm and inverse of  $e^x$ ) and

(t = travel time in days)

$t = \text{Ln} (M_t / M_o) / -k$

$t = \text{Ln} (0.001) / -0.275$

**t = 25.1 days**

Or alternatively determine the travel time in days by using Figure 2 graph- see below

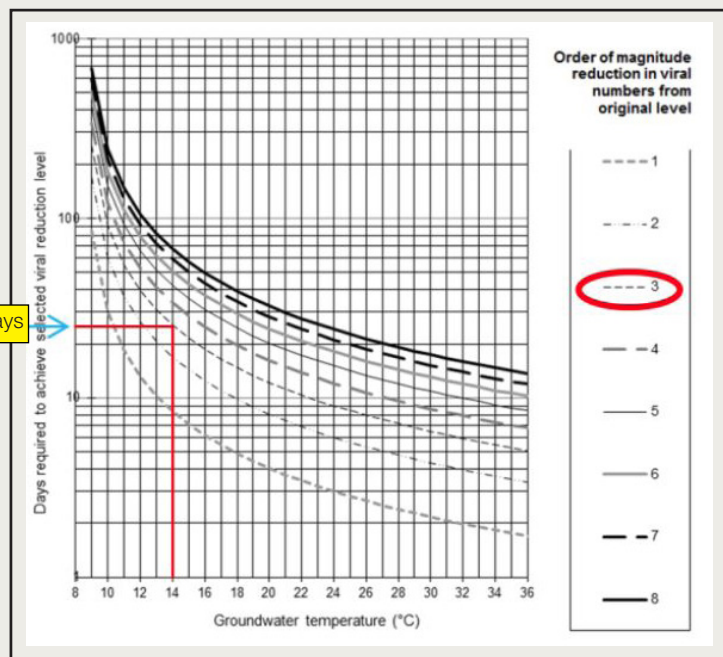

**Step B - Equation 2: Correcting Travel Time for Vertical Infiltration**

The time required for groundwater (containing viruses) to move a given distance in saturated material is estimated by using the formula below:

Formula:  $d_g = (t - d_v \cdot P/K) / (P/K \cdot i)$

$d_g$  = horizontal distance from effluent land application area to where virus die-off occurs (m)

$d_v$  = vertical distance to groundwater (m)

$t$  = travel time (days)

$P$  = porosity soil (fraction eg 0.3) - clay 40-70%, silt 35-50%, sand 25-50%, gravel 25-40%

$K$  = permeability (m/day)

$i$  = groundwater gradient (fraction eg 0.02 if slope of groundwater 1:50).

$d_g$  = horizontal distance from effluent land application area to where virus die-off occurs, we need to know this distance in metres?

$d_v$  = vertical distance to groundwater – eg 2m

$t$  = travel time in days – eg 25.1

$P$  = porosity soil – eg 0.3 (clay 40-70%, silt 35-50%, sand 25-50%, gravel 25-40%)

$K$  = permeability – eg 1.5 m/day (clay loam, moderate structure)

$i$  = groundwater gradient – eg 0.02 (slope of groundwater 1:50).

$$d_g = ((25.1 - 2 \times (0.3/1.5)) / (0.3/(1.5 \times 0.02)))$$

$$d_g = (24.7) / (10)$$

$$d_g = 2.47$$

$$d_g = \underline{2.5m}$$

**Recommended Safety Factor:**

There are a lot of variable inputs into the viral die-off equation, ie different soil layers, porosity and subjective soil permeability assessment. It is recommended to allow a safety factor of 2. This means to double the  $d_g$  answer (ie  $2.5m \times 2 = 5.0m$ )

The **improved viral die-off method for estimating setback distances** is an additional tool that the OSSM designer can use to further support a reduced setback distance determined by using AS/NZS 1547 Appendix R Method. It is not the intention to use the viral die-off setback distance method in the first instance when assessing the location of an effluent land application area or to determine the minimum separation distance from a site feature. When all other options have been considered and additional specifications applied to the OSSM design (eg treat the wastewater to a higher quality effluent standard, disinfection, pump the treated effluent further away from site constraint etc) then the viral die-off calculation can be used to further support the effluent land application location.

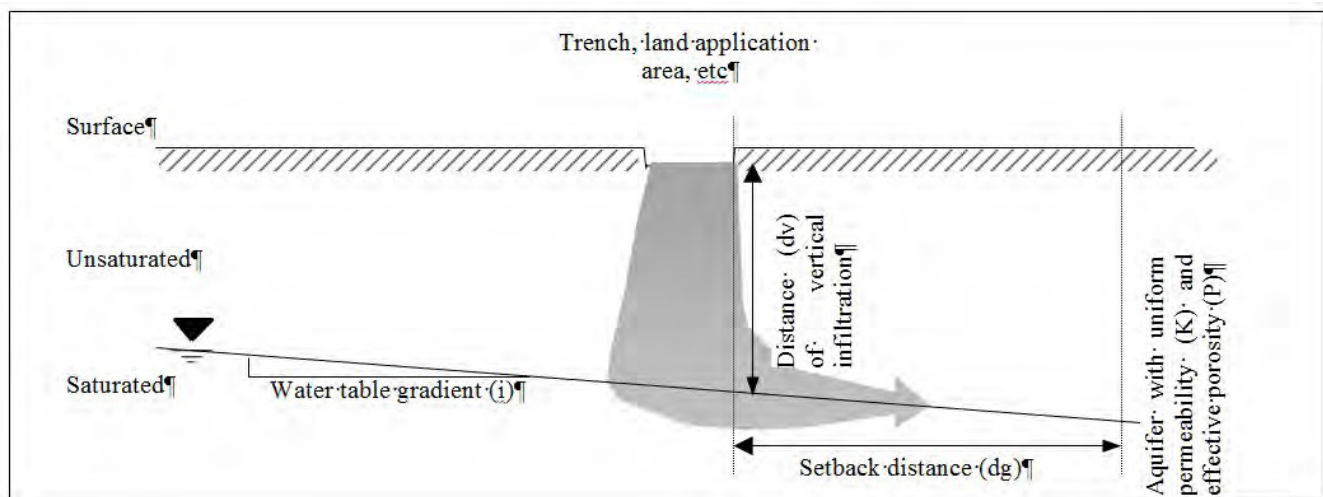

Cross section showing vertical infiltration of wastewater to a water table in a uniform soil.



## APPENDIX B - THE RADIUS OF INFLUENCE OF A WATER BORE (W C CROMER, E A GARDNER AND P D BEAVERS) - EXAMPLE

If an absorption trench or any similar effluent land application area is located inside the radius of influence of a bore, then there is potential for groundwater, contaminated with effluent, to enter the bore. The radius of influence of a bore can be estimated from aquifer pump tests or calculated from aquifer and bore hydraulic characteristics. This is an additional tool for the OSSM designer to support the minimum separation distance from an effluent land application area to a groundwater bore.

There are two steps involved in using the equation to estimate the radius of influence of a groundwater bore:

**Step 1** – Determine time (t) of pumping bore, in days. The value of (t) is to be greater than “1” for the radius of influence equation to be valid.

Formula:  $t = Kt / SH \geq 1$

- t → = time of pumping bore (days)
- K → = aquifer permeability (m/day)
- S → = porosity of aquifer (fraction eg 0.5 for clay, 0.3 for sand & 0.05 for rock)
- H → = thickness of water in bore, water bearing zone (m)

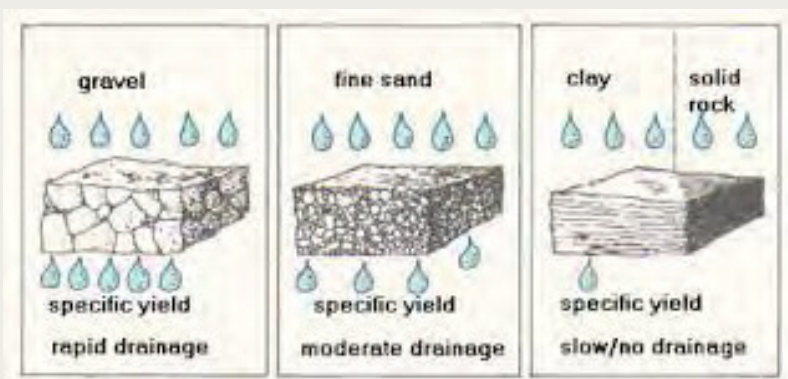

**Table 2.4 Range of Values of Porosity**

	n(%)
<b>Unconsolidated deposits</b>	
Gravel	25-40
Sand	25-50
Silt	35-50
Clay	40-70
<b>Rocks</b>	
Fractured basalt	5-50
Karst limestone	5-50
Sandstone	5-30
Limestone, dolomite	0-20
Shale	0-10
Fractured crystalline rock	0-10
Dense crystalline rock	0-5

**Step 2** – If Step 1 answer (t) is “≥ 1” then proceed to estimate radius (r) of influence of groundwater bore by using the following formula.

$$\text{Formula: } r = 1.5 \left[ \left( \frac{KHt}{S} \right)^{0.5} \right]$$

**Example:**

Aquifer permeability (K = 1.5m/day), water bearing zone (H = 8m from bore data), pumping time (t = 1 day), porosity of aquifer (S = 0.1 shale).

**Step 2 - Formula:**  $r = 1.5 \left[ \left( \frac{KHt}{S} \right)^{0.5} \right]$

$$r = 1.5 \times \left[ \left( \frac{1.5 \times 8 \times 1.9}{0.1} \right)^{0.5} \right]$$

$$r = 1.5 \times \left[ \left( \frac{22.8}{0.1} \right)^{0.5} \right]$$

$$r = 1.5 \times (228^{0.5})$$

$$r = 1.5 \times 15.1$$

$$r = 22.6\text{m}$$

The effluent land application area is to be located a minimum distance of 22.6m from the groundwater bore if the trench is located downgradient or cross gradient from the groundwater bore, refer below.

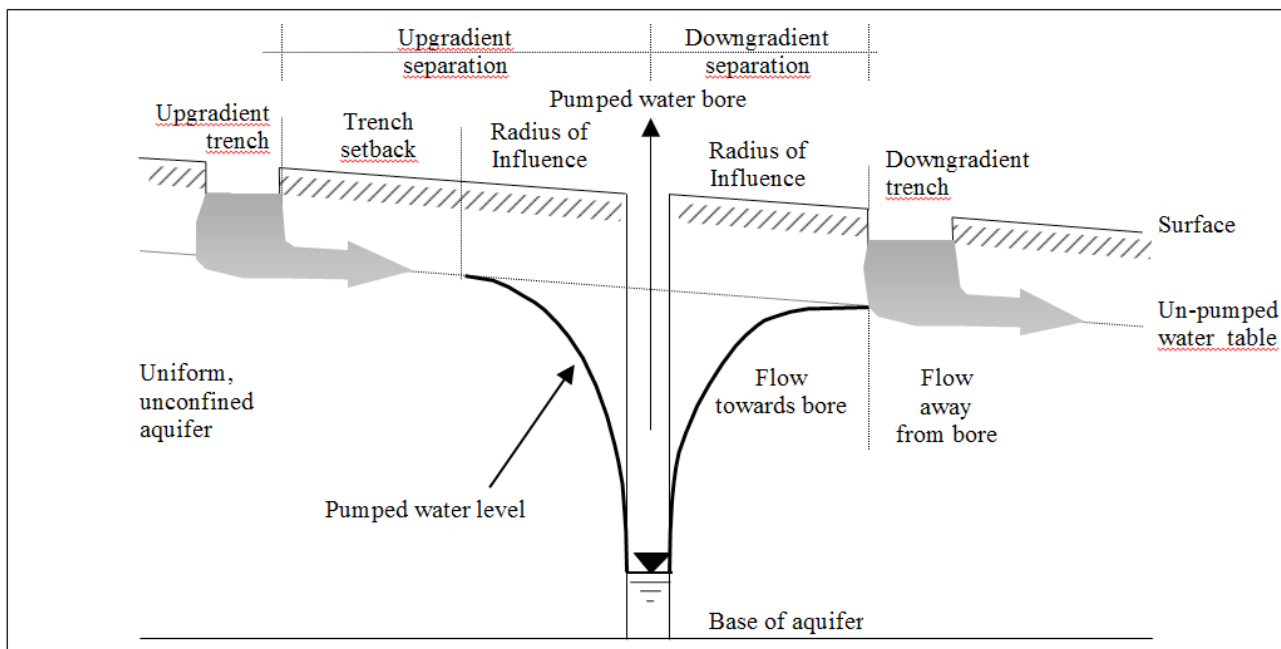

Downgradient and cross gradient absorption trenches can be located closer to water bores than up gradient trenches. The minimum separation distance for downgradient and cross gradient trenches should be the radius of influence of the bore. The minimum separation distance for up gradient trenches should be the radius of influence of the bore plus the setback distance for viral die-off.



## APPENDIX D – ETA BED - WATER BALANCE EXAMPLE

Parameters: Alstonville mean rainfall data, Alstonville pan-evaporation data, soil DLR 5mm/day, Wastewater volume – 3 bedroom – 4.5EP x 150 litres/EP = 675 litres/day

Site Address:		<b>ETA Bed Calculations</b>														
Input Data																
Wastewater flow	Q	675	L/day										150	Recommended coefficients in Water Balance:		
Daily Loading Rate	DLR	8	mm/day										3	Pan Evap/Crop: = 0.75 (eg grass)		
Crop factor	C	0.75	unit less										4.5	Retained Rainfall Fraction:		
Retained rainfall coefficient	RRC	0.75	unit less											Sand = 0.8, Medium Clay = 0.75, Heavy Clay = 0.7		
Media void space ratio	V	0.3	unit less										114	Media void space ratio - 0.3 gravel bed or 0.6 for plastic dome trench		
Rainfall data	Alstonville															
Evaporation data	Alstonville															
Parameter	Symbol	Formula	Units	Jan	Feb	Mar	Apr	May	Jun	Jul	Aug	Sept	Oct	Nov	Dec	Total
Days in month	D		days	31	28	31	30	31	30	31	31	30	31	30	31	
Rainfall	R		mm/month	178	225	261	197	182	165	94	75	56	109	133	153	1826.2
Evaporation	E		mm/month	176.7	140	133.3	105	83.7	72	83.7	108.5	132	155	162	182.9	1534.8
Crop factor	C			0.75	0.75	0.75	0.75	0.75	0.75	0.75	0.75	0.75	0.75	0.75	0.75	
<b>Outputs</b>																
Evapotranspiration	ET	ExC	mm/month	132.525	105	99.975	78.75	62.775	54	62.775	81.375	99	116.25	121.5	137.175	1151.1
Percolation	B	DIRxD	mm/month	248	224	248	240	248	240	248	248	240	248	240	248	2920
Outputs		ET+B	mm/month	380.525	329	347.975	318.75	310.775	294	310.775	329.375	339	364.25	361.5	385.175	4071.1
<b>Inputs</b>																
Retained rainfall	RR	RxRRC	mm/month	133.35	168.675	195.45	147.525	136.275	123.45	70.725	56.1	41.7	81.9	99.525	114.975	1369.65
Effluent irrigation	W	(QxD)/L	mm/month	183.6	165.8	183.6	177.6	183.6	177.6	183.6	183.6	177.6	183.6	177.6	183.6	2161.2
Inputs		RR+W	mm/month	316.9	334.5	379.0	325.2	319.8	301.1	254.3	239.7	219.3	265.5	277.2	298.5	3530.8
<b>Storage Calculation</b>																
Storage remaining from previous month			mm/month	0	0.0	18.2	121.6	143.0	173.2	196.8	8.5	0.0	0.0	0.0	0.0	
Storage for the month	S	(RR+W)-(ET+B)	mm/month	-63.6	5.5	31.0	6.4	9.1	7.1	-56.5	-89.7	-119.7	-98.8	-84.3	-86.6	-540.3
Cumulative storage	M		mm	0	18	122	143	173	197	8	0	0	0	0	0	0
Maximum effluent storage for worst month	N	mm														
Storage	V	NxL (litres)														
Water balance to achieve maximum 200mm storage for worst month		114	m <sup>2</sup>													



**Water Balance total ETA bed area needed = 114m<sup>2</sup>**

ETA bed depth = 500mm

Maximum effluent storage worst month is June, 197mm (which is &lt;200mm - ok)

Calculate ETA Bed Dimensions:

Area = 114m<sup>2</sup>

Length of Bed = Area / (Width bed)

Length of Bed = 114 m<sup>2</sup> / 2m

Length of Bed = 57m (total length of beds)

ETA Bed Dimensions – 3 x ETA beds – 19m long x 2m wide x 500mm deep

Hydraulic Load Method:

Area of Bed (A) = Q / DLR

Area (m<sup>2</sup>) = 675 litres / 8 DLRArea (m<sup>2</sup>) = 84.4m<sup>2</sup>Hydraulic Load Area = 84.4m<sup>2</sup>Water Balance Area = 114m<sup>2</sup>Nutrient Balance Area = Phosphorous 344m<sup>2</sup> - Nitrogen 443m<sup>2</sup>Effluent land application installation area = 114m<sup>2</sup> (Water Balance)Total effluent land application area = 443m<sup>2</sup> (Nutrient Balance).

The total effluent land application area is made up of the ETA bed installation + spaces between beds and additional land buffer downstream of installation.

## DEFINITIONS

**“Absorption”** absorption and/or uptake of effluent into soil by capillary action.

**“Absorption area/trench/bed”** a land application system which uses the principle of absorption.

**“Absorption Rate”** rate of discharge of water into soil.

**“Adsorption”** physical or chemical attachment of substances to the surface of soil particles.

**“Aerated Wastewater Treatment System (AWTS)”** a wastewater treatment process typically involving: settling of solids and flotation of scum; oxidation and consumption of organic matter through aeration; clarification - secondary settling of solids, and disinfection of wastewater before irrigation.

**“Batch System”** a composting toilet system involving two or more alternating chambers.

**“Biochemical Oxygen Demand (BOD)”** the amount of oxygen required for the biological decomposition of organic matter, measured over a period of 5 days (BOD<sup>5</sup>).

**“Boulder”** a rock with middle dimension greater than 600mm.

**“Compost Toilet”** treatment units which employ the process of biological degradation in which organic material is converted into humus like material through the action of micro-organisms and invertebrates.

**“Continuous System”** a composting toilet using a single chamber

**“Design Loading Rate”** the Long Term Acceptance Rate (LTAR) (see definition below), reduced by a factor of safety.

**“Dispersive soil”** a soil that has the ability in water to form a cloudy suspension that will not settle.

**“Distribution box”** a device which is designed to distribute filtered effluent evenly to separate irrigation areas. These devices are typically sized to accommodate the expected hydraulic load and should be mounted on a concrete plinth (min 100 mm thickness) to maintain the device level so as to ensure even distribution to irrigation fields. There should be no vehicle or animal stock traffic over the device.

**“Domestic”** up to and including ten (10) persons or maximum 2,000 L/day in a non commercial situation.

**“Durable aggregate”** aggregate, metal or stones which are graded to AS 2758.1 for single size coarse aggregate for nominal sizes, usually ranging from 20mm to 50mm.

**“Effluent filter”** placed in the outlet of septic or greywater tanks to reduce the level of solids entering the effluent disposal area. Effluent filters do not provide secondary treatment.

**“Effluent”** treated wastewater which has passed through a treatment system.

**“Evaporation”** the transfer of water from a liquid to a gas.

**“Evapo-transpiration”** removing water from soil by evaporation and from plants by transpiration.

**“Evapo-transpiration/absorption (ETA) bed”** a prepared bed or area which embodies the principals of evaporation, transpiration and absorption.

**“Faecal Coliforms”** a type of bacteria that live only in the gut of warm-blooded animals. Can be detected in the general environment if that environment is contaminated with human excreta, and therefore can act as an indicator of recent faecal contamination. Note that the faecal coliforms can also be due to the presence of faeces from other warm-blooded animals, ie livestock or birds.

**“Geotextile”** a water permeable material used in foundation stabilisation, soil particles moved by water erosion are designed not to pass thorough the geotextile fabric (care should be taken as there are different fabric spacing sizes and qualities).

**“Greywater”** the component of domestic wastewater which excludes water closet (toilet) and urinal wastes.

**“Greywater Diversion Device (GDD)”** – a GDD is a watermarked approved hand activated switch that diverts untreated Greywater by gravity or pump directly to sub surface irrigation system. GDD's are not permitted to be installed in unsewered areas in BSC.

**“Greywater Treatment System (GTS)”** a system that collects, stores, treats, and may disinfect, greywater to the standards specified within NSW Ministry of Health - Domestic Greywater Treatment Systems.

**“Groundwater”** the body of water in the soil, all the pores of which is saturated with water; includes water below the water table and seepage from springs etc.

**“Indexing Valve”** allows for a number of separate land application areas to be irrigated.

**“Irrigation Systems”** pressurised sub-surface irrigation systems with pressure compensating emitters, (ie effluent disposal). These systems may incorporate an indexing valve (ie K-rain valve). These all require secondary treated effluent with disinfection, and are installed as “sub-surface irrigation” (300mm to 100mm depth) in accordance with the NSW Ministry of Health requirements.

**“Infiltration”** the passage of water into the soil.

**“Land Application Area (LAA)”** the area over which treated wastewater is applied ie disposal area.

**“Long Term Acceptance Rate (LTAR)”** the long term average rate effluent water can be absorbed into the natural soil at a selected disposal site, expressed in litres per square metre per day (L/m<sup>2</sup>/day). This rate is influenced by effluent water quality, method of dosing, the soil permeability and the slime layer interface equilibrium of the receiving soil.

**“Pan Evaporation”** the loss of water by evaporation measured in a Class A pan under controlled conditions.

**“Pathogens”** micro-organisms that are potentially disease causing; these include, but are not limited to bacteria, protozoa and viruses.

**“Percolation”** a general term describing the rate of water movement through a soil or through a biological mat within an effluent disposal area.

**“Permeability”** a calculated value derived from the rate at which a head of liquid is absorbed into soil, usually measured in m/d as Saturated Hydraulic Conductivity (Ksat).

**“Primary Treatment”** the separation of suspended material from wastewater by settlement and/or floatation in septic tanks, primary settling chambers etc, prior to effluent discharge to either a secondary-treatment process, or to a land-application system.

**“Scum”** the floatable material which accumulates on the liquid during primary wastewater treatment; material includes oils, grease, soaps and plastics.

**“Secondary Treatment”** aerobic biological processing and settling or filtering of effluent received from a primary treatment unit. Effluent quality following secondary treatment is expected to be equal to or better than 20 mg/L BOD<sup>5</sup> and 30 mg/L suspended solids.

**“Secondary Treatment with disinfection”** Effluent quality following disinfection shall meet the NSW Ministry of Health requirement and is expected to be equal to or less than (90% of samples) 20 mg/L BOD<sup>5</sup>, 30 mg/L Suspended Solids, 10 cfu/100ml faecal coliforms and minimum 0.5 mg/L and maximum 5.0 mg/L Free Available Chlorine (FAC) where chlorine is used as disinfection.

**“Septic Tank”** wastewater treatment device that provides a preliminary form of treatment for wastewater, comprising sedimentation of suspended solids, flotation of oils and fats, and anaerobic digestion of sludge.