



# *ossm* *owner* education booklet

---

AN INFORMATION BOOKLET FOR  
EXISTING AND FUTURE ON-SITE SEWAGE  
MANAGEMENT (OSSM) OWNERS



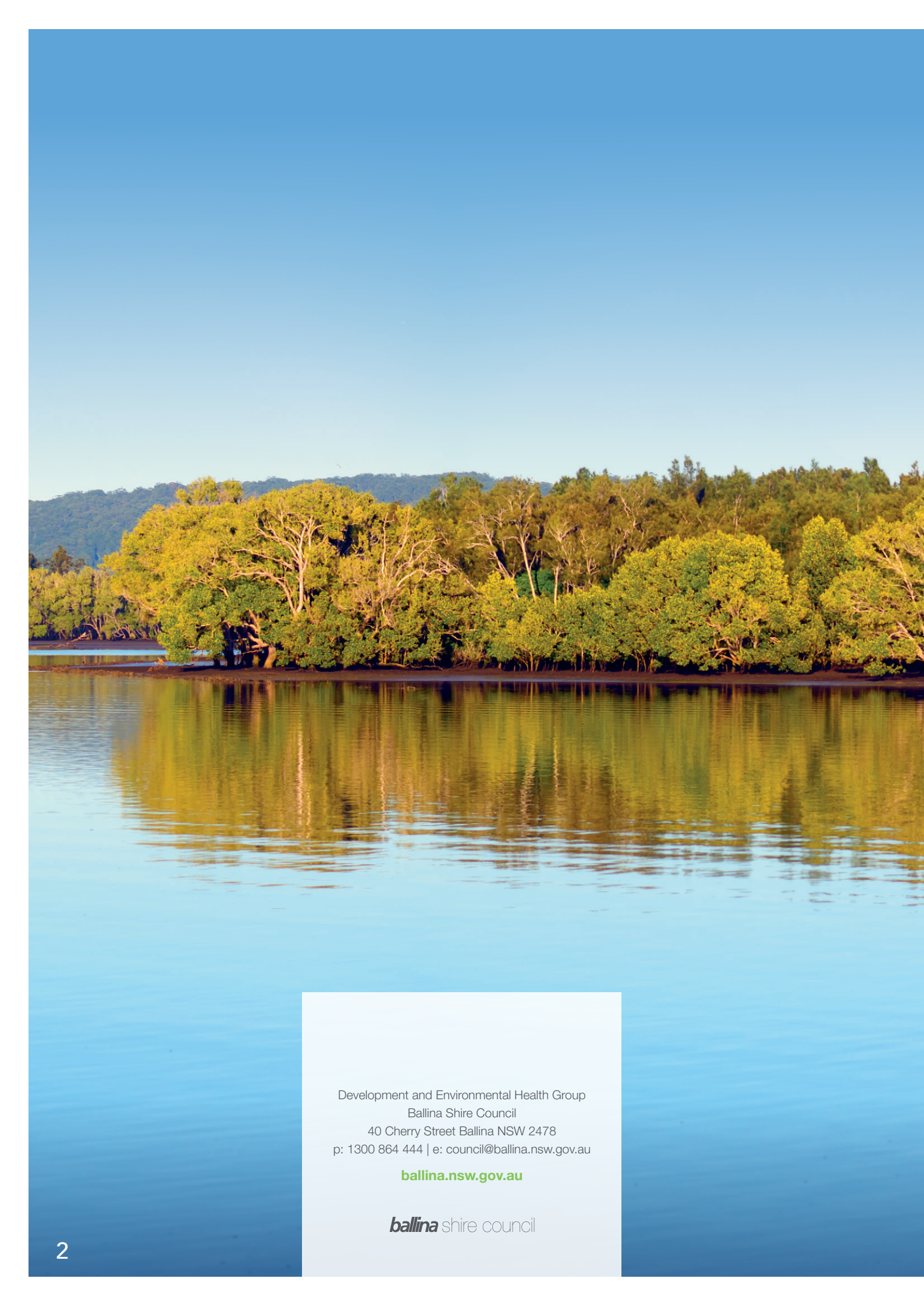

Development and Environmental Health Group  
Ballina Shire Council  
40 Cherry Street Ballina NSW 2478  
p: 1300 864 444 | e: council@ballina.nsw.gov.au

[ballina.nsw.gov.au](http://ballina.nsw.gov.au)

**ballina** shire council





## **contents**

<b>INTRODUCTION</b>	<b>4</b>
<b>WHAT IS AN OSSM SYSTEM</b>	<b>5</b>
<b>CHOOSING AN OSSM SYSTEM</b>	<b>6</b>
<b>WASTEWATER TREATMENT LEVELS</b>	<b>7</b>
<b>TYPES OF OSSM SYSTEMS</b>	<b>8</b>
<b>CESS PITS OR PAN TOILETS</b>	<b>14</b>
<b>CHOOSING AN EFFLUENT LAND APPLICATION SYSTEM</b>	<b>14</b>
<b>SPECIAL COMPONENTS USED IN EFFLUENT LAND APPLICATION AREAS</b>	<b>17</b>
<b>HOLDING TANKS / PUMP WELLS</b>	<b>18</b>
<b>WATER AND ENERGY EFFICIENCY</b>	<b>19</b>
<b>MANAGEMENT AND MAINTENANCE OF YOUR OSSM SYSTEM</b>	<b>20</b>
<b>FURTHER INFORMATION – REFERENCES</b>	<b>22</b>



## *introduction*

A key objective of Ballina Shire Council's (BSC) On-Site Sewage Management (OSSM) Strategy is to provide an education program to assist homeowners maintain their OSSM system in a satisfactory condition. This OSSM owner education booklet has been prepared with the homeowner in mind and is one of several educational initiatives proposed.

BSC is aware of the need to provide the mechanism and facility for an OSSM owner to learn basic knowledge of how their system operates and how it is to be maintained.

The satisfactory performance of an OSSM system is susceptible to the operation and maintenance practices of the homeowner.

The educational booklet provides information for existing and future OSSM owners on the fundamentals on how to choose an OSSM system, how it works and how to maintain the system. Additional OSSM educational information is also provided on the BSC website.

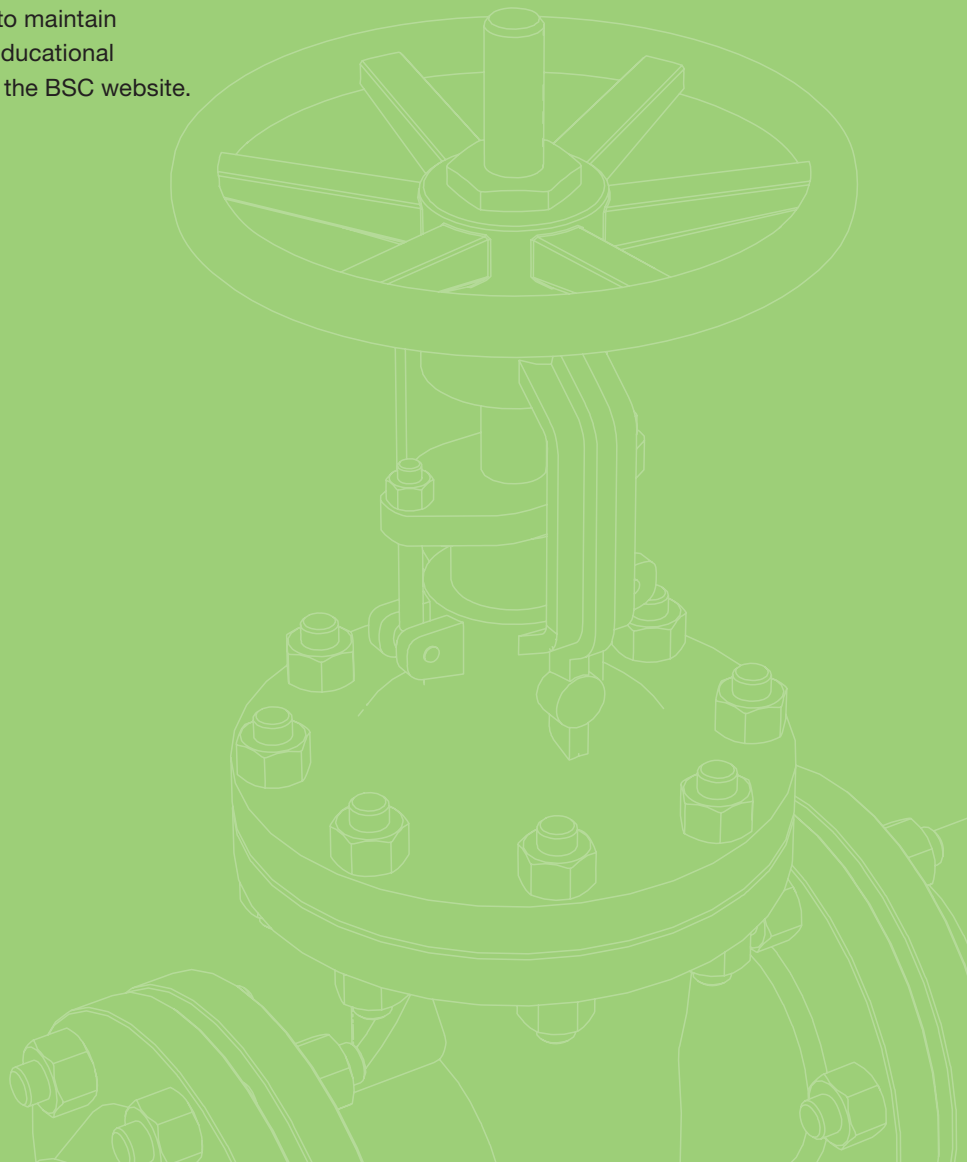



## *what is an ossm system*

OSSM systems treat the wastewater generated from premises located in non-sewered regions and apply the effluent into the environment (land) via sub-surface methods. Typical OSSM systems include septic tanks, aerated wastewater treatment systems, composting toilets, reed beds, sand filters, biological filters, and greywater systems. The treated wastewater (effluent) is applied to the land according to the site constraints utilising various land application methods ie absorption/evapotranspiration beds and trenches, Wisconsin sand mounds and subsurface irrigation systems.

Surface irrigation of effluent is not permitted within the BSC Local Government Area (LGA) for all new applications to install a OSSM system, however if the property owner has an existing OSSM system installed with a BSC approved surface irrigation system then this system may continue to operate in this way as long as the system is regularly serviced, maintained and operates satisfactorily. If the surface irrigation system is not maintained, serviced at the required intervals and/or is not operating satisfactorily then BSC will issue the owner an "Order" to apply the effluent to the land using a sub-surface method.





## *choosing an ossm system*

This section provides information to assist the homeowner in selecting the most suitable treatment system that will satisfy their needs and adequately deal with any site constraints (such as close proximity to waterway or small block size). For each treatment system, general information is given regarding its function and form, and technical information relevant to the operation and maintenance of each system is contained in checklists accessible on BSC website.

The OSSM designer and owner should be aware that each system will require some monitoring and maintenance. The extent of monitoring and maintenance will vary depending on the type of system selected. Highly mechanised systems such as aerated wastewater treatment systems and sub-surface irrigation fields generally have quarterly maintenance requirements (four per year); whilst some other type of systems need only be checked and maintained by a suitably qualified person at least once every three years (refer to Section 4 in BSC OSSM Strategy). The financial costs associated with monitoring and maintaining an OSSM system is another important factor to consider when choosing an OSSM system.





## wastewater treatment levels

### PRIMARY TREATMENT

Primary treatment refers to the physical removal of solids and organic matter through settling and sedimentation. Wastewater collection tanks for raw effluent (ie septic and greywater tanks) provide significant primary treatment through settlement and anaerobic digestion of organic solids by microbes. Primary treatment results in an effluent that is lower in suspended solids and biochemical oxygen demand (organic matter), but does not significantly reduce nutrient levels. The level of primary treatment depends on the residence time of the sewage in the tank (the storage/ treatment time of wastewater as it moves through the tank from inlet to outlet pipework), which in turn depends on the size of the tank, the volume occupied by scum and sludge layers and the household daily wastewater volume generated.

### SECONDARY TREATMENT

For the purpose of these guidelines, the term “secondary treatment” applies to systems which produce the results in Table 1 (see below). By reducing the concentration of nutrients and suspended materials, the level of effluent treatment has a proportional impact on the size of the effluent land application area required. For further information on OSSM effluent compliance criteria, including nutrient reduction parameters, refer to AS 1546.3 – Aerated Wastewater Treatment Systems.

### GREYWATER TREATMENT

“Greywater” (or sullage) is the term used for all household wastewater excluding toilet wastes, for example when a composting toilet is installed, all other wastewater generated is greywater. Greywater generally contains lower nutrients but can still contain significant levels of pathogens, eg from showering and nappy washing. The NSW Ministry of Health requires greywater to be disposed of below ground level unless it has been adequately disinfected.

Greywater must be collected in a tank (accredited and sized in accordance with NSW Ministry of Health requirements) where primary treatment can occur, before being dispersed into the soil. Where the site is unconstrained, it can be piped directly from a tank into a suitably sized sub-surface effluent land application system, but it should be understood that this is likely to reduce the operational life of the effluent land application system. It is recommended that effluent from the greywater tank be further filtered and/or treated before being applied to the land (eg in a reed-bed or sandfilter).

The size of the effluent land application area required to safely disperse greywater depends on the household wastewater volumes generated, quality of inputs, soil permeability and is to be calculated using water and nutrient balance equations.

### DISINFECTION

There are a number of options for effective long-term disinfection for OSSM systems. Chlorination is commonly used with AWTSSs. However some systems also use bromine, ultraviolet light or ozone as disinfectants. In general, if the effluent is applied greater than >300mm below ground surface level then no disinfection is required, but if the effluent is applied less than <300mm below ground surface level then disinfection is required, refer to NSW Ministry of Health Advisory Note 4 - Recommended Final Uses of Effluent Based on the Type of Treatment.

Any form of disinfection requires a well clarified effluent, low in organic matter and suspended solids (ie secondary treatment) in order to be effective. Care is to be taken to ensure that contact with sewage can be kept to an absolute minimum during routine maintenance and that no residents or neighbours will be exposed to effluent (potential pathogens) during normal operation of the OSSM system.

Table 1: Secondary Treatment Wastewater Quality Standard

PARAMETER	SECONDARY EFFLUENT	
	(90% OF SAMPLES)	MAXIMUM
Biochemical Oxygen Demand (BOD <sub>5</sub> )	≤ 20 mg/L	30 mg/L
Total Suspended Solids (TSS)	≤ 30 mg/L	45 mg/L
Escherichia Coliforms (E.coli)	≤ 10 cfu/100ml	30 cfu/100ml
Free Available Chlorine (FAC) (Where chlorine is used as disinfection)	Minimum 0.5 mg/L	5.0 mg/L



## » types of ossm systems

### SEPTIC AND GREYWATER TANKS

The septic tank used for single houses is a small anaerobic settlement and digestion plant, which reduces suspended solids from the wastewater and breaks them down to smaller particles. The resultant effluent is lower in settled solids but still high in biological oxygen demand (BOD), nutrients and potentially pathogens. Modern septic tanks have been improved by the installation of at least one internal baffle to reduce solids carry-over and to provide sufficient opportunity for settlement of solids.

When the wastewater from the house reaches the septic tank, most solids settle to the bottom (commonly termed “sludge”) whilst most fats, oils and greases float to the top to form a crust (commonly termed “scum”), and the middle zone is occupied by a liquid called effluent.

The addition of enzymes and bacteria supplements may assist in reducing the amount of sludge build-up in the septic tank, therefore increasing the time interval between the pumping out of the tank and also may reduce offensive odours.

Induct vents are no longer required on septic tanks as it is considered that the sanitary drainage educt vent provides sufficient venting of the septic tank. The omission of the induct vent has also reduced the potential for ingress of surface water, flies, mosquitoes and rodents into the tank where they can breed. For a larger septic tank size (>3000 Litres), grease traps are no longer required. Smaller grease traps are not recommended as they need regular maintenance and have sometimes been found to be too small to trap grease effectively. Kitchen wastewater can

be connected directly into an appropriately sized septic tank with a baffle installed.

The Australian Standard for septic tanks is AS/NZS 1546.1. All septic tanks need to be manufactured in accordance with this standard and have an appropriate Standards Mark on the tank. The NSW Ministry of Health provides an accreditation process for the manufacturing of septic tanks and wastewater collection wells.

The sizing of septic tanks and wastewater collection wells shall be in accordance with NSW Ministry of Health “Sewage Management Facility Vessel Accreditation Guideline”. Septic tank sizes are nominated for domestic flows of up to 14,000 Litres per week or daily flows of 2000 Litres. The serviceable life of the tank is stated as 15 years. If the calculated size of tank is not available (manufactured) then BSC requires that the next largest manufactured tank size to be installed.

The location of the septic tank must be, in general, at a greater distance than 1.5m from any building and an angle of elevation of at least 45° (angle of repose) between the bottom of building/structure footing and the base of the tank. Allowances must also be made for easy access to the tank in order for the pumping contractor to remove contents from the tank during the desludging process.

Surface water is to be diverted away from the tank installation to ensure that there is no ingress of surface water into the tank. Special design measures need to be specified when a tank is installed in high groundwater or flood prone areas.

Figure 1: Cross-section of septic tank

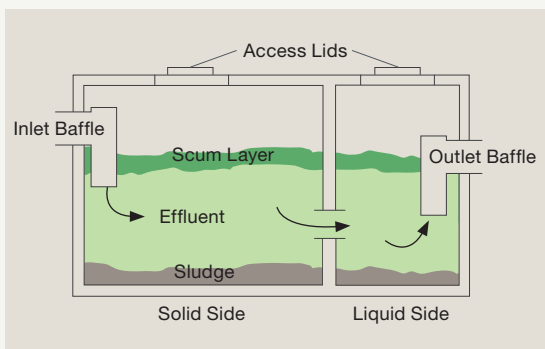

Figure 2: Septic tank installation





## EFFLUENT FILTERS

An effluent filter is a coarse screen filter that fits into the outlet of a primary treatment tank (septic tank). Effluent filters reduce Total Suspended Solids (TSS) carry over and thereby extend the operational life of effluent land application areas. These types of filters are recommended to be fitted on the outlets of both septic and greywater tanks.

It is recommended that the effluent filter should be of a robust type and accessible for ease of maintenance.

The outlet filter can be cleaned by jetting water through it, while positioned over the primary compartment of the septic tank, using a suitable hose attachment (ie hose “wand”).

Homeowners shall be made aware if an outlet filter has been installed in their septic tank and the frequency and mode of cleaning before a particular filter is selected. Personal protective clothing and equipment is to be worn when performing this activity ie long sleeves, pants, gloves, glasses and wash hands when finished.

*Figure 3: Position of septic tank outlet filter inside PVC pipe – outlet tee junction*



*Figure 4: Cleaning of septic tank outlet filter – (Sydney Catchment Authority)*

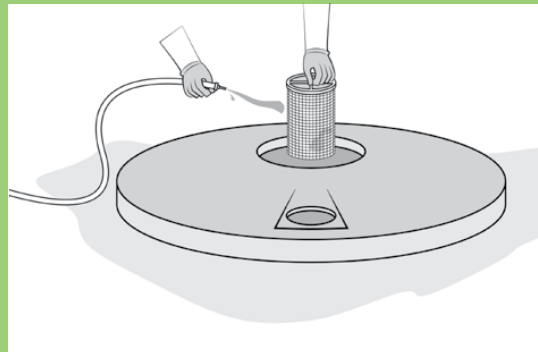

### WATERLESS COMPOST TOILETS

The function of a waterless composting toilet is to collect and treat human excreta and any other added organic material and bulking agents from a single dwelling or non-domestic installation. Compost toilets significantly reduce the amount of treatment required for sewage by separating faeces and urine from the wastewater stream at the source.

When considering the installation of a compost toilet the important questions to ask are; where will the toilet be located? how many people will be using the toilet? and whether it will be operating on a continuous basis or only occasionally? such as in a holiday house.

The composting process requires little or no added water with the excess liquid in the form of urine and condensation removed from the solid waste and treated separately into a small evapotranspiration/absorption trench (refer manufacturer's instructions). The composting process converts the solid waste to a safer, more stable and less offensive composted end product. At the completion of the composting process, the composted end product shall be incorporated into the soil or removed for disposal in a manner approved by BSC.

By eliminating the need for toilet flushing, they also reduce household water usage by as much as 30%. Consequently, the size and complexity of the treatment component of the OSSM system can be significantly reduced.

Nevertheless, it should be noted that compost toilets still generate a small amount of leachate that will need to be directed into the greywater management system or alternatively into a separate small trench.

Figure 5: Cross-section of composting toilet operation process. (Australian Government – Your Home)

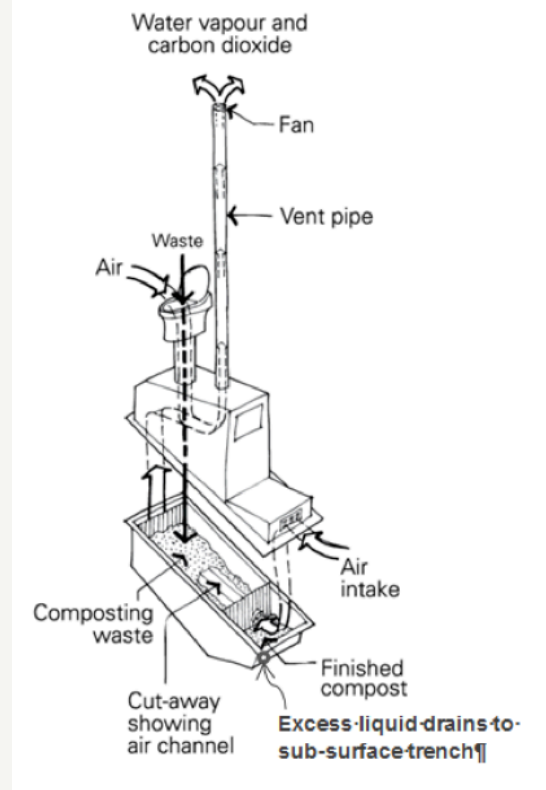

Figure 6: Typical position of composting toilet unit below floor and under toilet.



Figure 7: Compost toilet – example of wood shavings, used as bulking agent, added to compost toilet after use.



Depending on the size and design, waterless composting toilets are either installed with a toilet pan pedestal above floor level and the collection chamber(s) of the waterless composting toilet below floor level; or completely free-standing on the floor in the case of smaller units.

Dry composting toilets require a carbon-based material or bulking agent, such as dry leaves or softwood shavings to be frequently added to the container, preferably daily or with each use. This bulking agent gives the proper carbon–nitrogen mix, prevents odours, helps aerate the pile and prevents compacting. The toilets must be vented and some have mechanical ventilation to ensure good air flow around the compost heap. After a period of time faecal and bulking material is decomposed into a friable humus-like compost material, which is removed from an access opening at the base of the toilet. In general for composted material, yellow is “poor” and black is “good”.

Leachate from the compost toilet can be directed into the greywater tank (if applicable) or its own designated trench. The leachate can actually help the biological process in the greywater tank by adding valuable bacteria. If a reedbed is used the nutrients in the leachate help promote reed growth. Leachate management must be included in any treatment design that involves the use of a compost toilet.

The use of a compost toilet will remove the toilet component from the wastewater flow of a dwelling or development. However, the household greywater and the liquid wastes from the composting toilet will still need to be collected and treated in an appropriate manner. Greywater can be treated in conventional septic tanks, AWTs, reed beds, or in other systems specifically designed and approved for greywater.

It is important to ensure that flies and rodents are excluded from the interior of the toilet. Thus, stainless steel fly-wire should be placed over any exposed ventilation openings and the toilet lid is to be kept closed when not in use. It is also important to minimise the introduction of excessive moisture into the compost heap when hosing or cleaning the compost toilet.



## *safety tips*

- » The degree of decomposition and pathogen destruction is sensitive to a range of ambient conditions in the composting mass (such as temperature, moisture and pH levels), which is difficult for the toilet owner to monitor and control. It is safest to assume that the composted end-product contains residual disease-causing pathogens
- » Always use protective clothing such as gloves and mask when handling the composted end-product
- » Bury the compost under at least 10cm of soil
- » Do not use the compost for cultivating vegetables.



### AERATED WASTEWATER TREATMENT SYSTEM (AWTS)

AWTSs are small-scale package treatment plants that have similar treatment processes to a large-scale (municipal) sewage treatment facility. They typically produce effluent which, with sufficient filtering, can be distributed straight into a sub-surface dispersal system.

In general an AWTS includes an anaerobic and aerobic treatment zone and a number of pumps. AWTSs typically settle solids and float scum in the first anaerobic chamber, much like a septic tank, and then aerate the effluent in a second chamber. The aerobic process usually consists of injecting compressed air into the effluent to promote the growth of aerobic bacteria for further treatment (plastic media is also usually installed in this chamber to create an environment to increase bacteria growth). A third treatment process is carried out in the settling chamber to clarify the effluent prior to disinfection and pumping out of the effluent into the land application area.

Failure or a sustained interruption to any part of the AWTS, eg as a result of power interruptions or when a tourist dwelling is unoccupied during the off-season, can lead to a period of poor treatment performance until sufficient micro-organisms are once again restored to adequately treat the effluent.

AWTSs require regular (quarterly) servicing to ensure the satisfactory operation of treatment processes, pumps, high level alarms and that adequate disinfection (ie chlorination) is maintained. This servicing is a requirement stipulated in the AWTS NSW Ministry of Health Accreditation. The power consumption, quarterly servicing and maintenance costs associated with an AWTS need to be considered and budgeted for when selecting an OSSM system.

Homeowners should be aware that sub-surface irrigation emitters may tend to get blocked if high nutrient loads cause a build-up of bio-matter in the soil pores surrounding the emitters, and that periodic dosing of chlorine should be considered in these cases. Other ways to avoid this problem is to use non-drain emitters or emitters which release miniscule doses of root inhibitor to prevent root intrusion and reduce biomass production in the immediate vicinity of the emitter.

All AWTSs are to be accredited by the NSW Ministry of Health pursuant to the Local Government (General) Regulations 2005. The AWTS must be installed in accordance with the accreditation conditions.

Figure 8: Cross-section of AWTS and the treatment process. (Environment & Health Protection Guidelines)

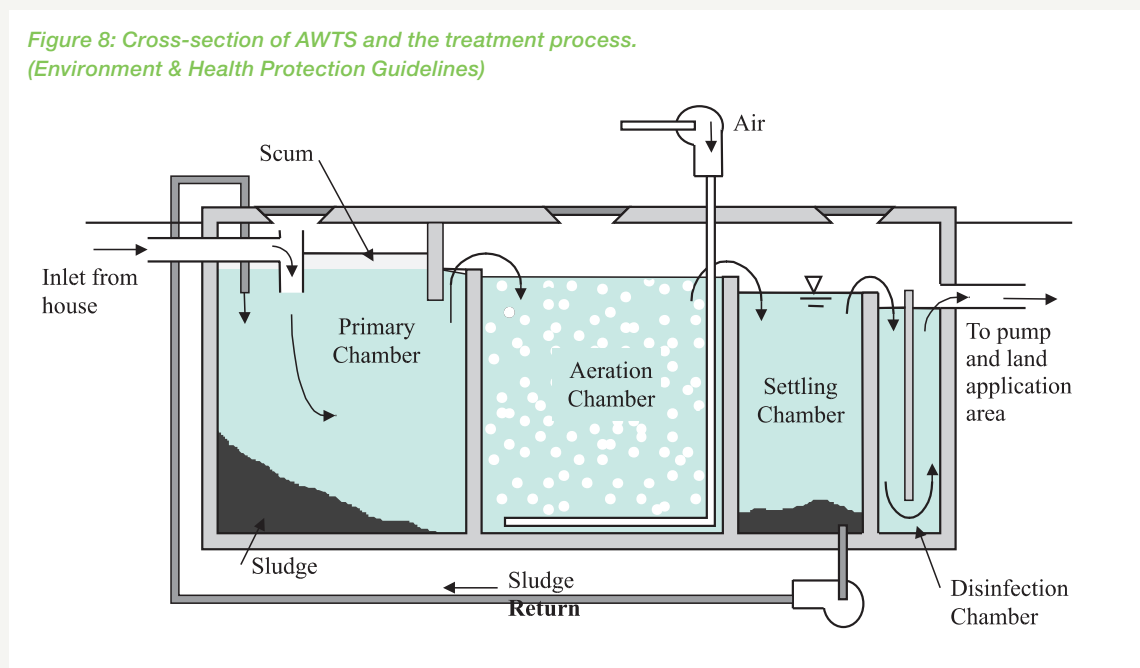



**REED BEDS (SUB-SURFACE FLOW - CONSTRUCTED WETLANDS)**

*Figure 9: Indicative reed bed treatment process.*

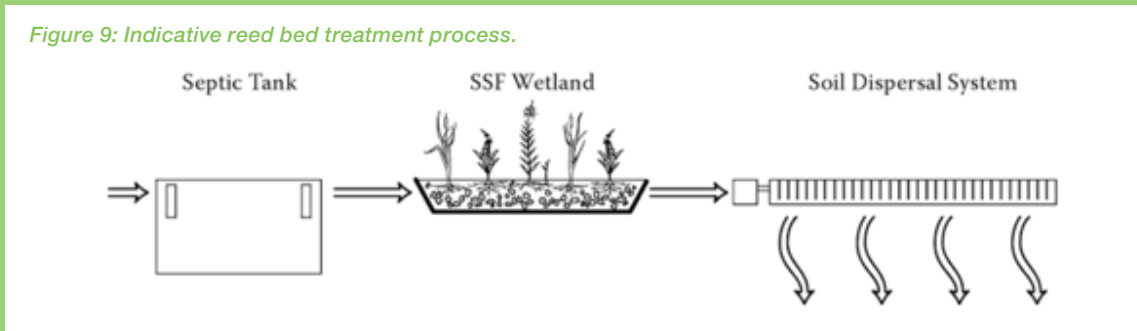

Reed beds comprise a constructed impermeable vessel in which water or effluent is kept slightly below the surface of a gravel substrate, which supports the growth of wetland plants (usually reeds). The effluent is biologically treated as it moves slowly through the root zone of the wetland plants from inlet to outlet points. In order to minimise the risk of infection and disease through physical contact with the effluent, reed-beds should be constructed in a way that keeps the top of the effluent at least 5cm below the top of the gravel bed. Reed beds are usually constructed from solid moulds such as plastic tanks or concrete troughs.

Reed-beds are an increasingly popular type of secondary treatment device due to their aesthetic appeal, their treatment performance capacities once the reeds are fully established, and their somewhat lower construction and servicing costs and maintenance requirements compared to other options. They are also passive devices not necessarily reliant upon power or pumps, and therefore economical to operate in the long term.

The design and installation of reed beds for sewage treatment is a specialised field. Treatment performance is largely dictated by the time (termed “residence time”) that the primary-

treated effluent spends in the reed bed, as this determines the contact-time of effluent with the bacteria-coated gravel and roots in the bed.

Various reeds/macrophytes have been used in reed beds with species from the genera *Phragmites*, *Schoenoplectus* and *Typha* being the most commonly used. Macrophytes that have been successfully used in this region are *Schoenoplectus validus* (river club rush), *Typha orientalis* (bull rush), *Phragmites australis* (common reed), *Bolboschoenus fluviatilis* (marsh clubrush), *Lepironia articulata* (grey rush), *Baumea articulata* (jointed twigrush), *Lomandra hystrix* (not longifolia) and *Carex bichenoviana*.

Tube stock for most wetland plant species may be purchased from nurseries that specialise in wetland plants. These plants can also be propagated vegetatively by dividing root clumps obtained from existing constructed wetlands. An initial planting density of 3 plants/m<sup>2</sup> is recommended for new installations.

Lismore City Council has developed a document titled “The use of Reed Beds for the Treatment of Sewage and Wastewater from Domestic Households”. If you are considering installing a reed bed it is recommended that you refer to this document.

*Figure 10: Reed bed under construction.*



**CESS PIT OR PAN TOILETS**

Due to the high risk these types of toilets pose to public and environment health, the cess pit or pan toilets are not recommended by BSC. Existing cess pits or pan toilets that are operating unsatisfactory will need to be upgraded in accordance with current requirements and an appropriate toilet system installed ie composting toilet.



## choosing an effluent land application system

The level of wastewater treatment plus site and soil-specific parameters largely determine the appropriate effluent land application system for any given situation, but cost and maintenance requirements are also relevant in making the necessary choices. The strengths and weaknesses of various effluent land application systems are summarised in APPENDIX K AS/NZS 1547: (2012), whilst a brief description of each option is provided in the following.

### ABSORPTION TRENCHES

Absorption trenches rely on infiltration of effluent into the soil beneath the trench. Historically this was the only wastewater dispersal method used in the region, irrespective of the soil type. Absorption trenches do not provide for substantial re-use as the effluent is concentrated below the root zone, forcing most of the water downwards to potentially pollute underlying groundwater. They are prone to failure in clay soils due to clogging and hydraulic overloading.

Figure 11: Absorption trench under construction.



Figure 12: Absorption trench under construction.



### EVAPO-TRANSPIRATION ABSORPTION (ETA) BEDS

ETA beds are wider and shallower than traditional absorption trenches, thereby providing a much greater opportunity for effluent uptake by plants and reduce the dependence on infiltration and soil assimilation capacities to treat the effluent. As well as providing treatment and reuse of a proportion of the effluent through evapo-transpiration, ETA beds can be quite robust and need relatively little maintenance when properly designed and installed.

Owners of ETA beds should maintain appropriate vegetation on the beds. Mowed grass is the preferred vegetation cover, although shrubs and trees can be planted suitable distances away from the edge of ETA beds.

Figure 13: ETA bed under construction.



Figure 14: ETA bed under construction.



### WISCONSIN SAND MOUND SYSTEMS

Sand mound systems are effluent dispersal devices constructed above the ground surface from imported specific sand material and capped with appropriate loam to clay-loam soil. In general these raised sand mounds are used in situations where drainage of the natural soil is restricted, or where the underlying groundwater seasonally reaches a height of less than 1.2 m below ground level, or areas where periodic flooding occurs. Effluent dispersal is mainly by evapotranspiration and some absorption through the sand mound and underlying soil. Denitrification may be achieved within mounded effluent land-application systems by using intermittent dose loading.

Figure 15: Sand mound under construction.



Figure 16: Sand mound covered with turf.



Specialist design and installation advice is required for this type of installation due to the effluent dispersal system needed, difficulties in construction and the adverse environmental consequences of system failure. If a sand mound system is proposed, the design and sizing of each mound shall be in accordance with AS/NZS 1547.

Sand mound systems must be carefully constructed and turfed to prevent erosion and to maximise shedding of rainfall off the mound. It should be noted that specific sand is required and not all sand suppliers/quarries can supply the required clean medium grain sand needed for constructing a sand mound.

BSC requires that the sand to be used in the construction of Wisconsin Sand Mound be analysed by an accredited soil laboratory. The sand is to have an effective grain size ranging from 0.25 – 1.00mm, a uniform co-efficient of <4, percentage of fines <3% passing through a 200 sieve (0.074mm) and free of clay, limestone and organic material (ie washed sand). A copy of the laboratory analysis is to be provided to the BSC OSSM Officer before installation.

Figure 17: Photos of typical sand media grain sizes.



Fine Grain Sand

Medium Grain Sand

Course Grain Sand



## SUB-SURFACE IRRIGATION

Sub-surface irrigation (SSI), also commonly referred to as sub-surface drip irrigation (SDI), is a good method of distributing treated effluent because it can distribute small, measured doses to evenly spaced outlets in relatively undisturbed soil. This ensures a very reliable distribution available for rapid root uptake, and minimises the risk of the irrigation field becoming saturated during extended rainfall. Sub-surface irrigation is particularly appropriate where there are site or soil limitations, such as steep slopes, heavy clay impermeable (often termed “puggy”) soils, and even on highly permeable sandy soils.

The design of pumped sub-surface irrigation systems for domestic wastewater requires a competent understanding of pumps, pipes and emitters. For this reason, sub-surface irrigation systems must be designed, certified, installed and maintained by suitably qualified people. The sub-surface irrigation design and installation must comply with the requirements of AS/NZS 1547.

*Figure 17: Sub-surface irrigation system under construction.*



*Figure 18: Sub-surface irrigation system under construction.*



## EFFLUENT LAND APPLICATION AREA CONSIDERATIONS

Subsurface land application systems are preferred as they minimise the potential for human contact and rapid release to the environment (Stewart et al, 1983). Evapotranspiration mechanisms are considered the most environmentally suitable means of managing treated effluent because of the ability of the plants to reduce pollution loads while at the same time enhancing the beauty of the locality. The northern rivers subtropical climate allows for a large range of plants to be selected for this purpose compared to other parts of NSW.

Effluent land application systems can get overloaded with effluent and fail over time. It is recommended that an alternate/reserve land application area be set aside for future use should the primary effluent land application area become less able to accept effluent. It is recognised that some existing properties do not have sufficient room for an alternative/reserve effluent land application area. In these cases it is important that a higher level of wastewater treatment be performed, and effluent is alternated into a different section of the effluent land application area after each pump cycle (if possible, using an indexing valve), thereby allowing each area to have a “rest” in an unsaturated state for significant periods each day.





## *special components used in effluent land application areas*

Besides the effluent land application methods described on previous pages, there are a number of important auxiliary components which are generally incorporated into effluent land application systems.

### INDEXING VALVES

Indexing valves allow for up to six separate land application areas (beds or irrigation zones) to be used. The indexing valve will apply a set volume of effluent to the first effluent land application area, after which the pump turns off and the indexing valve automatically switches to the next application area outlet where the process is repeated.

*Figure 19: Typical indexing valve.*



### DOSING SIPHONS

Gravity-driven dosing siphons are unpowered devices that ensure effluent reaches the treatment or dispersal system in a periodic “slug” rather than a constant dribble, thus providing more even distribution and more successful treatment and/or dispersal of effluent. Dosing siphons are generally located after the collection tank (grey or blackwater) to deliver effluent to ETA beds. They are recommended in sloping sites where a fall of over at least 1m exists between system elements to enable the dosing siphon to operate.

*Figure 20: Example of dosing siphon.*

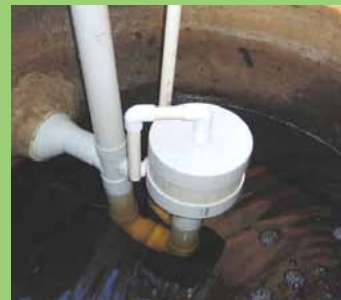

## » holding tanks / pump wells

Many modern OSSM systems require pumping effluent to or from various components, and this generally necessitates either an internal or external pump. Pump wells, also commonly referred to as holding tanks or collection wells, enable the storage of effluent until it reaches a pre-set level in the tank at which time a pump is activated and the accumulated effluent is pumped through to the next component or the land application system.

The sizing of pump wells shall be in accordance with the advice provided by NSW Ministry of Health in their “Septic Tank and Collection Well Accreditation Guideline”. Smaller holding tanks are acceptable for dosing siphons which have no opportunity for mechanical break-down. Audio and/or visual alarms must be installed in a manner that will alert the homeowner to the presence of a high-level condition in the tank.

Figure 21: Demand dose pump well –float valve arrangement. (Sydney Catchment Authority)

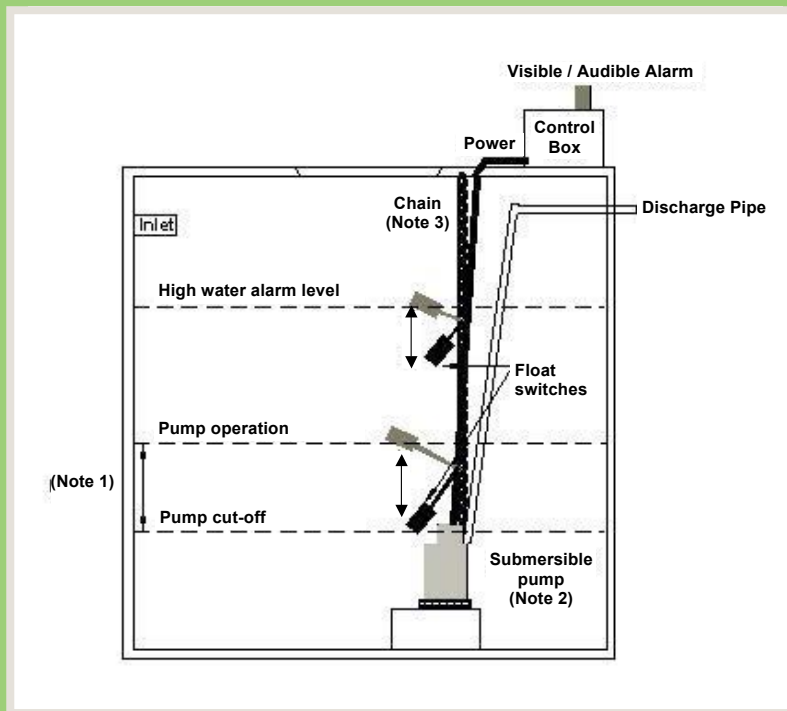



## water and energy efficiency

All buildings connected to OSSM systems will benefit from the installation of water and energy efficient plumbing products. These products will conserve the water and energy supply, minimise wastewater generation, assist in the satisfactory operation of the OSSM system and reduce the risk of the system failing. Refer to the Australian Government Water Efficiency Labelling Standards (WELS) Scheme and Energy Rating websites to compare the water and energy efficiency of different products.

### For a standard residential dwelling the following water efficient products are to be installed:

- Water conserving clothes washing and dishwashing machines (if applicable);
- Dual flush cisterns to all toilets;
- Flow control aerators to taps (except bath spout and hose taps); and
- Water conserving shower roses.

The WELS water rating label provides water efficiency information for water-using products. It allows consumers to compare products and rewards manufacturers and retailers who make and stock water efficient models.

A zero to six star rating allows a quick comparative assessment of the product's water or energy efficiency. The more stars on the label the more water or energy efficient the product. A figure showing the water consumption flow of the product based on laboratory tests is also indicated.

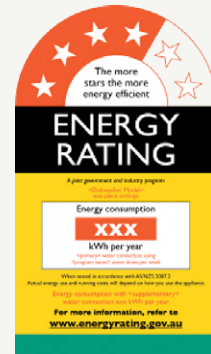

### By saving water you will also save energy

It takes energy to treat, transfer and heat water. The less water you use, the less energy you use and the less greenhouse gases you create.

### Additional OSSM design elements to consider:

- use of electricity
- use of consumables (such as chlorine)
- frequency of servicing
- number of parts and maintenance costs
- generation of greenhouse gases
- ability to reduce a) organic matter (compost food scraps), b) nutrients (low phosphorus washing and cleaning products), c) salts (low sodium washing and cleaning products) and sludge.



## *management and maintenance of your ossm system*

The effective operation of the OSSM system and effluent land application area will, in part, depend on how it is managed and maintained. A small amount of maintenance work performed regularly can prevent your system from failing. The following is a guide on how to achieve the most from your system.

### **Things to do**

- Ensure your OSSM system is the appropriate design for the area. Inappropriate systems can pollute the natural environment and pose health risks to humans
- Regularly maintain the effluent land application area. Long grass and weeds reduce the evapotranspiration efficiency. Cut and remove grass clippings from the disposal area
- Have your septic tank de-sludged every three to five years to prevent sludge build up, which may 'clog' the pipes and absorption trenches
- Prevent the entry of stormwater onto the effluent land application area by constructing a diversion drain upslope. Direct the stormwater around the area, but not into neighbouring properties
- Ensure your tank is well sealed. This prevents the entry of vermin and mosquitoes
- Conserve Water. The less water you use the drier the effluent land application area will be, especially through the cooler months
- Check household products for suitability for use with an OSSM system. Use biodegradable liquid detergents, with low phosphorous and low sodium
- Have your grease trap (if installed) cleaned out regularly ie every three months
- Know the location and layout of your OSSM system and effluent land application area
- Keep a record of pumping, inspections, and other maintenance.

### **Things not to do**

- Don't allow livestock to graze on the effluent land application area. This can lead to compaction and collapse of the area
- Don't put large quantities of bleaches, disinfectants, whiteners, nappy soakers and spot removers into your OSSM system via the sink, washing machine or toilet. These products can kill off the good bacteria needed to breakdown wastewater solids
- Don't allow any foreign materials such as nappies, sanitary napkins, condoms or other hygiene products to enter the OSSM system
- Don't put fats and oils down the drain and keep food waste out of your OSSM system
- Don't install or use a garbage grinder or spa bath if your OSSM system is not designed for it.

The effective operation of the OSSM system and effluent land application area will, in part, depend on how it is managed and maintained. A small amount of maintenance work performed regularly can prevent your system from failing.





*Don't treat your absorption area like this.*

**What to do if there is a problem with your OSSM system and/or effluent land application area**

If there is a problem with your OSSM system or effluent land application area that has potential to impact on the environment or public health then you must by law do something about it. Indications of a problem include foul smells from the tank or effluent land application area, toilets and drains that back up or drain slowly, high water level inside the septic tank, no de-sludging of tank in the last 5 years or a wet/soggy effluent land application area. Do not ignore the problem, it will only get worse and could cost you more money in the long term.

For regulatory advice prior to carrying out any alterations/modifications to existing systems or the installation of a new system you should contact BSC Development and Environmental Health Group.

For operational problems with an existing OSSM system you should contact a suitably qualified person ie authorised service agent for aerated wastewater treatment systems or a licensed plumber and drainer for septic systems.



## *further information – references*

NSW Department of Local Government at [www.dlg.nsw.gov.au](http://www.dlg.nsw.gov.au). This site has a large amount of information about current and past on-site wastewater management programs and documents such as the On-site Wastewater Risk Assessment System (OSRAS).

NSW Ministry of Health at <http://www.health.nsw.gov.au/environment/domesticwastewater/Pages/default.aspx>. Information on the accreditation of wastewater management facilities by NSW Health is also available on the NSW Health web site.

Sydney Catchment Authority – Design and Installation of On-site Wastewater Management Systems  
<http://www.sca.nsw.gov.au/publications/publications/designing-and-installing-on-site-wastewater-systems>

Irrigation Australia's list of Certified Irrigation Designer's  
<http://irrigation.org.au/certification/listing-of-certified-irrigation-designers>

NSW Ministry of Health - Advisory Note 4 - Recommended final uses of effluent based on the type of treatment

<http://www.health.nsw.gov.au/environment/domesticwastewater/Pages/default.aspx>

Lismore City Council - The use of reed beds for the treatment of sewage  
[https://www.lismore.nsw.gov.au/cp\\_themes/default/page.asp?p=DOC-WDY-07-81-63](https://www.lismore.nsw.gov.au/cp_themes/default/page.asp?p=DOC-WDY-07-81-63)

BALLINA SHIRE COUNCIL DOCUMENTS

- On Site Sewage Management Strategy - 2017
- On Site Sewage Management Guidelines - 2017
- Factsheet 1 - What is an on site sewage management system
- Factsheet 2 - How a basic septic tank works
- Factsheet 3 - Management of your septic tank
- Factsheet 4 - Care and maintenance of your on site sewage management system
- Factsheet 5 - Water conservation and your on site sewage management system|
- Factsheet 6 - Roles and responsibilities
- Factsheet 7 - Septic tank decommissioning procedure and pumpout contractors
- Factsheet 8 - On site sewage management complaints
- Factsheet 9 - On site sewage management fee
- Factsheet 10 - Commercial OSSM applications >10EP guide for consultants
- Factsheet 11 - Priority oyster aquaculture areas guide to OSSM consultants
- Factsheet 12 - NSW oyster industry sustainable aquaculture strategy extracts
- Factsheet 13 - Setback distances for effluent land application systems
- Factsheet 14 - Development Applications key points to be addressed in OSSM reports
- Factsheet 15 - Flood events and on site sewage management systems

These checklists can be downloaded from Council's website [www.ballina.nsw.gov.au](http://www.ballina.nsw.gov.au)

- OSSM - Inspection Checklist – Septic Tank, Pump Well, Collection Well
- OSSM - Inspection Checklist – Septic Trench / Bed
- OSSM - Inspection Checklist – Composting Toilet
- OSSM - Inspection Checklist – Wisconsin Sand Mound
- OSSM - Inspection Checklist – Sub-Surface Irrigation Area

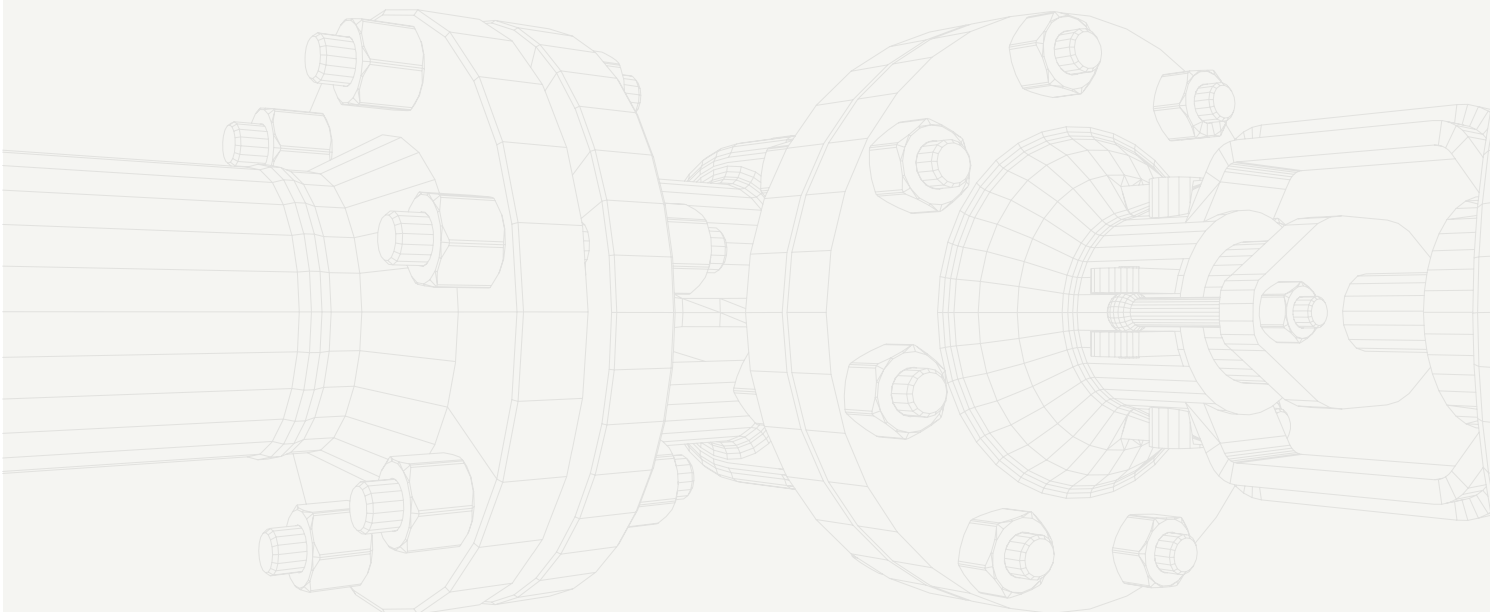



Development and Environmental Health Group  
Ballina Shire Council  
40 Cherry Street Ballina NSW 2478  
p: 1300 864 444 | e: council@ballina.nsw.gov.au

[ballina.nsw.gov.au](http://ballina.nsw.gov.au)

**ballina** shire council